

# EcoSystem™ | Bus Supply Installation Guide

**ATTENTION: Please read this guide before installing**

## Contents

Ratings	1
Model Number Explanation	1
Overview	2
EcoSystem Bus Supply and Enclosure Mounting	3
Mains Voltage Wiring	4
EcoSystem Bus Wiring	5
Emergency Input	6
Optional Contact Closure Inputs	7
Testing and Troubleshooting	9
Warranty and Contacts	12

## Ratings for all models:

- Input: 100 - 277 V $\sim$  180 mA 50 / 60 Hz
- Output: 18 V $\text{---}$  250 mA (per bus) max.
- Operating Environment: 0 - 40 °C (32 - 104 °F), < 90% relative humidity, non-condensing

## Model Number Explanation

<b>CS -</b>	-
<b>1L:</b> Powers 1 EcoSystem Bus	<b>CM:</b> Unit not shipped with an enclosure
<b>2L:</b> Powers 2 independent EcoSystem busses	<b>WM:</b> Unit premounted in UL-listed 8 x 8 x 4 in. (203 x 203 x 102 mm) enclosure or larger

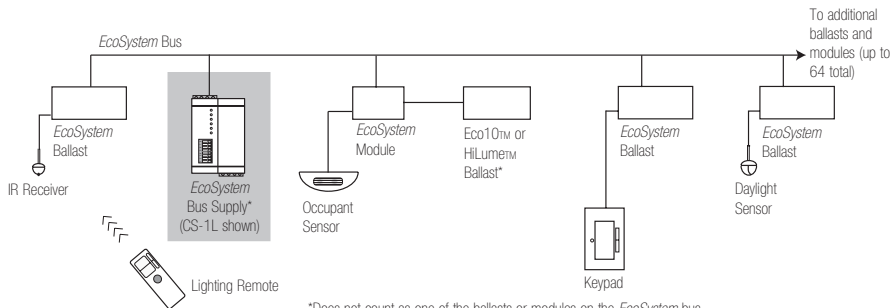

\*Does not count as one of the ballasts or modules on the EcoSystem bus

# EcoSystem™ | Bus Supply Installation Guide

## Overview

The *EcoSystem* Bus Supply powers one or two *EcoSystem* Buses and supports communication for a maximum of 64 ballasts and modules per Bus. An *EcoSystem* lighting network consists of a Bus Supply, ballasts, modules, sensors, and keypads. The diagram on the previous page shows a typical system topology.

All ballasts, modules, and the Bus Supply are powered by mains voltage (Hot/Live and Neutral) and require two additional wires for digital communication (E1 and E2). The *EcoSystem* Bus may be run in the same conduit as mains wiring or separated from mains wiring. The *EcoSystem* Bus can be wired with any topology: the *EcoSystem* Bus wires are non-polarized, and can be run as a daisy chain, T-tap, star pattern, or any combination. Only one *EcoSystem* Bus Supply is allowed per *EcoSystem* lighting network.

- 64 total ballasts and modules
- 8 daylight sensors
- 64 occupant sensors
- 64 total keypads or infrared receivers

Refer to the following step by step guide for proper *EcoSystem* Bus Supply installation.

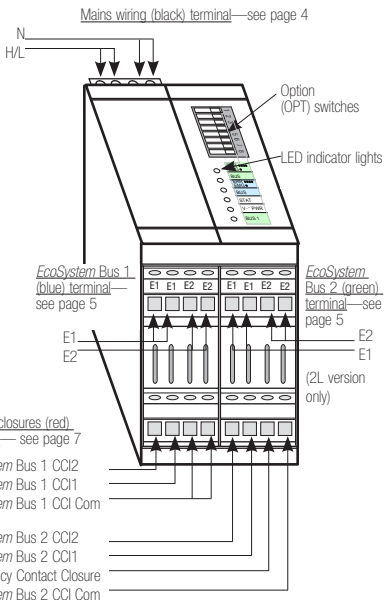

# EcoSystem™ | Bus Supply Installation Guide

## Step 1: EcoSystem Bus Supply and Enclosure Mounting

**Note:** Mount the *EcoSystem* Bus Supply in a location where it can be easily located and accessed if servicing or troubleshooting is necessary. The bus supply can be mounted in any orientation (if required).

- A. Select a UL-listed NEMA Type 1 (or better) electrical enclosure with minimum dimensions of 8 in. x 8 in. x 4 in. (203 mm x 203 mm x 102 mm) (l x w x d) or mount the WM version using the mounting holes provided and skip to Step 2. *EcoSystem* Bus Supply external dimensions are shown in illustrations at right.
- B. Mount UL-listed enclosure per enclosure's instructions.
- C. Mount DIN rail (included with *EcoSystem* Bus Supply) horizontally near the center of the enclosure.
- D. Clip the *EcoSystem* Bus Supply onto DIN rail:
  1. Hook the *EcoSystem* Bus Supply to the top of the DIN rail
  2. Using a screwdriver, pull the DIN rail clip out and away from the DIN rail
  3. Pivot the *EcoSystem* Bus Supply onto the DIN rail
  4. Release the DIN rail clip

(The *EcoSystem* Bus Supply can be removed, if necessary, by reversing this procedure.)

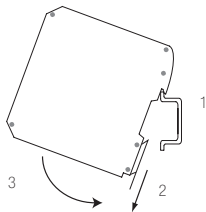

## Clip EcoSystem Bus Supply onto DIN Rail

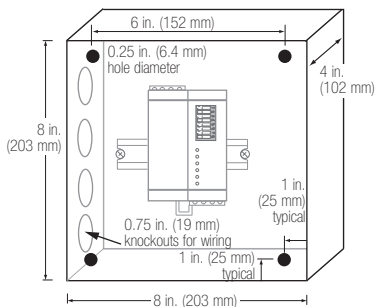

## Mounting Holes & Dimensions of CS-1L/2L-WM

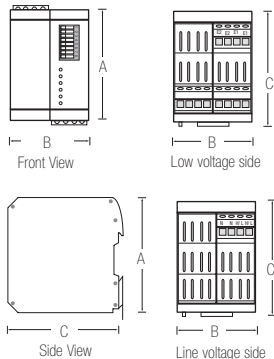

A = 3.56 in. (85 mm)

B = 1.77 in. (45 mm)

C = 3.62 in. (92 mm)

## Dimensions of CS-1L/2L-CM (CS-1L shown)

# EcoSystem™ | Bus Supply Installation Guide

## Step 2: Mains Voltage Wiring

The *EcoSystem* Bus Supply operates at 100-277 V $\sim$ . Use the following instructions to properly wire line voltage to the *EcoSystem* Bus Supply.



**DO NOT WIRE LIVE!** Interrupt power via circuit breaker before wiring or servicing the *EcoSystem* Bus Supply.

- Use #12 to #18 AWG (2.5 to 1.0 mm<sup>2</sup>) conductors to feed mains wiring (100-277 V $\sim$ ). The device draws less than 120 mA.
- Wire mains to the black terminals labeled N and H/L. Four terminals are provided, two for Neutral (N) and two for Hot/Live (H/L). Redundant terminals provide for easy wiring of mains to other modules if needed.
- The *EcoSystem* Bus Supply is grounded via the DIN rail through clips on the bottom of the module. Attach ground wire to DIN rail via the green terminal block (provided on WM version only) or to DIN rail mounting screw.
- Turn on circuit breaker to energize the *EcoSystem* Bus Supply. V $\sim$  PWR indicator on the *EcoSystem* Bus Supply will light green when properly energized. If the indicator does not light, verify line voltage wiring.

**Emergency Lighting:** When the power to the *EcoSystem* Bus Supply is removed, the *EcoSystem* Bus Supply signals to ballasts and modules powered by emergency/essential power to go to their programmed emergency light level (100% by default). For this reason, the *EcoSystem* Bus Supply should not be powered via an emergency/essential lighting circuit.

**Note:** If additional wiring space is necessary, the *EcoSystem* Bus Supply can be removed from the DIN rail while wiring. Follow the instructions in Step 1: *EcoSystem* Bus Supply and Enclosure Mounting for details.

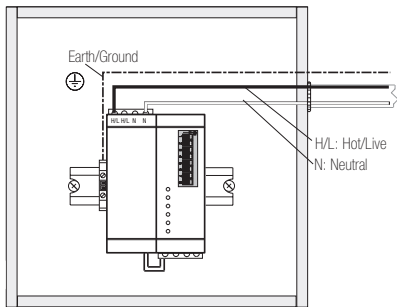

**Mains Wiring to *EcoSystem* Bus Supply**  
(CS-1L-WM shown)

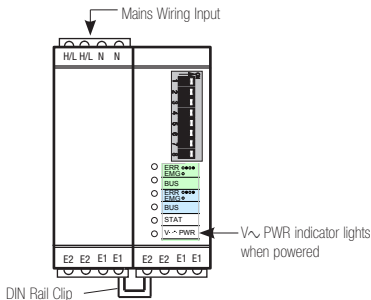

**Front View of *EcoSystem* Bus Supply**  
(CS-2L version shown)

## Step 3: EcoSystem Bus Wiring

*EcoSystem* Bus wiring may be considered NEC® Class 1 or PELV (Class 2: USA).

- NEC® Class 1: Low voltage *EcoSystem* Bus wiring may be run in the same conduit as mains voltage wiring to fixtures.
- PELV (Class 2: USA): Low voltage *EcoSystem* Bus wiring must be separated from all mains and NEC® Class 1 wiring.

Consult applicable national and local codes for compliance.

Lutron recommends using two different colors for E1 and E2 (*EcoSystem* Bus) wires. This will prevent wiring mistakes in junction boxes where several different *EcoSystem* Bus wires combine. Use the following instructions for wiring the *EcoSystem* Bus.



**DO NOT WIRE LIVE!** Interrupt power via circuit breaker before wiring and servicing the *EcoSystem* Bus Supply.  $V \sim$  PWR indicator will be off when power is off.

- Use the wire size chart that follows to determine which wire size to use based on the length of the *EcoSystem* Bus.
- Wire the *EcoSystem* Bus from terminal E1 and terminal E2 to all ballasts and modules.
- Separate low-voltage wiring from the mains wiring. If wiring the *EcoSystem* Bus as PELV (Class 2: USA), maintain proper separation from mains and NEC® Class 1 wiring.
- Turn on circuit breaker to energize.  $V \sim$  PWR indicator lights green when energized.
- EcoSystem* Bus Supply outputs 17 V $\pm$  1 V $\pm$  (maximum) between E1 and E2. Use a voltage meter to confirm this voltage between E1 and E2 terminals. Confirm that there is no voltage from E1 to earth/ground or from E2 to earth/ground. Otherwise, a wiring fault is present, which must be cleared before continuing.

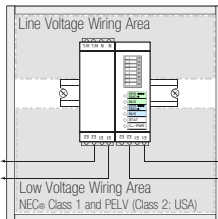

To first bus ballasts and modules

To second bus ballasts and modules (2L version only)

## EcoSystem Bus Wiring to EcoSystem Bus Supply

Note separate areas for different voltage wiring

**Note:** If 17 V $\pm$  +/- 1 V $\pm$  is not present between E1 and E2, check *EcoSystem* Bus wiring. A short between E1 and E2 will cause the *EcoSystem* Bus supply to stop providing voltage on the bus and will cause the corresponding ERR indicator to flash. Removing the short between E1 and E2 will automatically allow the *EcoSystem* Bus Supply to operate properly.

## Wiring Size and Bus Length

*EcoSystem* Bus wires E1 and E2 are not polarity sensitive. *EcoSystem* Bus length is limited by the wire gauge used for E1 and E2 as follows:

Wire Gauge	Maximum <i>EcoSystem</i> Bus Length
#12 AWG (4.0 mm <sup>2</sup> )	2200 ft (671 m)
#14 AWG (2.5 mm <sup>2</sup> )	1400 ft (427 m)
#16 AWG (1.5 mm <sup>2</sup> )	900 ft (275 m)
#18 AWG (1.0 mm <sup>2</sup> )	570 ft (175 m)

## Step 4: Emergency Input

The Emergency Input on the *EcoSystem* Bus Supply is compatible with an external normally-closed contact closure output. Normally closed means that the contact is closed when normal power is present. The contact is open when normal power is lost.

When the input to CCI-EMERG (terminal Em) is not connected to CCI-COM (terminal C) and OPT Switch 5 (Emergency Disable) is in the Off position, the entire *EcoSystem* Bus is in Emergency mode. When in Emergency mode, all ballasts and modules will be at their programmed emergency output (100% light by default). Also, all control and programming of a ballast or module will be disabled while it is in Emergency mode.

If using a 2L version, there is only one Emergency input; it affects both busses.

## Emergency Input Wiring (if used)

The *EcoSystem* Bus Supply is compatible with fire alarms and security systems that have a normally-closed (NC) contact closure output. Contact closure input may be dry contact closure or open collector (NPN). To use the Emergency input with an external normally-closed relay, follow these steps:



**DO NOT WIRE LIVE!** Interrupt power via circuit breaker before wiring and servicing the *EcoSystem* Bus Supply.  $V \sim$  PWR indicator is off when power is off.

- A. Wire the alarm system's normally-closed contactor between CCI-COM (terminal C) and CCI-EMERG (terminal Em) on the red terminal block. Use #12 AWG to #18 AWG (2.5-1.0 mm<sup>2</sup>) between the *EcoSystem* Bus Supply and contactor terminals. See the diagram on the next page.
- B. Ensure that OPT Switch 5 (Emergency Disable) is in the Off position.
- C. Turn on circuit breaker to energize.  $V \sim$  PWR indicator on the *EcoSystem* Bus Supply glows green when energized.

## Step 5: Optional Contact Closure Inputs

Contact closure inputs (CCI) on the *EcoSystem* Bus Supply may be used for integrating a BMS system or occupant sensors with contact closure outputs (CCO) to an *EcoSystem* Lighting Network.

If the contact closure inputs on the *EcoSystem* Bus Supply are not used, skip to Step 6: Testing and Troubleshooting.

If using a 2L version, there is one set of contact closure inputs per bus. The contact closure inputs for each bus are located beneath the corresponding *EcoSystem* Bus terminals.

Contact Closure Input 1 (CCI-1) and Contact Closure Input 2 (CCI-2) can be programmed to control two different groups of ballasts or modules (one group per CCI). CCIs force the assigned groups to an "Occupied mode" or "Unoccupied mode". Groups are assigned using the *EcoSystem* Programmer.

Occupied mode enables the system to operate normally: wall controls, daylight sensors, and infrared transmitters control ballasts as programmed. Unoccupied mode turns *EcoSystem* ballasts and modules off.

A ballast or module can be programmed to listen to a combination of occupant sensors (connected to ballasts on the *EcoSystem* Bus) and/or contact closure inputs (CCIs) on the *EcoSystem* Bus Supply. These programmable inputs determine whether a ballast or module is in occupied mode or unoccupied mode. A ballast or module will be in unoccupied mode if all occupant sensors or Bus Supply CCIs that are programmed to control the ballast and module are in the unoccupied state. If any occupant sensors or Bus Supply CCIs are in the occupied state, all ballasts or modules that they are programmed to control will be in the occupied mode.

# EcoSystem™ | Bus Supply Installation Guide

Each Bus Supply CCI input may be configured as normally open (NO) or normally closed (NC) (see OPT Switches on page 8). Inputs may be dry contact closure or open collector (NPN) with the following specifications:

- On-state saturation voltage less than 2.0 V $\overline{\text{---}}$
- Off-state leakage current less than 10  $\mu\text{A}$
- Minimum open circuit voltage rating 24 V $\overline{\text{---}}$
- Minimum current rating 10 mA

## PELV (Class 2: USA) Terminals

Terminal	Unit Label	Function
C	COM	Common
Em	CCI-EMERG	Emergency
A	CCI-1	Contact Closure 1
B	CCI-2	Contact Closure 2

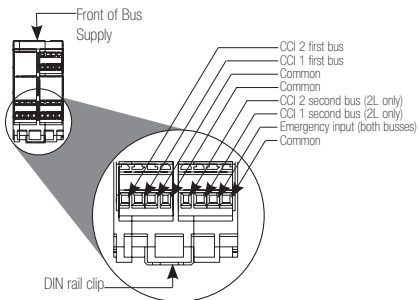

## Contact Closure Input Wiring

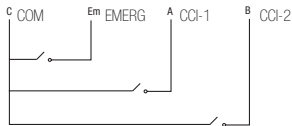

## Contact Closure Input Wiring (if used)

Contact closures from a building automation system may be wired directly to the *EcoSystem* Bus Supply.

Contact Closure Inputs on the *EcoSystem* Bus Supply are programmed to control ballasts and modules through the *EcoSystem* Programmer.

Use the following instructions to wire external contact closure outputs to the *EcoSystem* Bus Supply. Distance from contact closures to the *EcoSystem* Bus Supply is limited to 200 feet (61 m). Wire may be #12 AWG to #22 AWG (2.5-0.5 mm $^2$ ).



**DO NOT WIRE LIVE!** Interrupt power via circuit breaker before wiring and servicing.  $V\sim$  PWR indicator is off when power is off.

- Wire between the contact closure relay to CCI-1 (terminal A) or CCI-2 (terminal B) and COM (terminal C) on the red terminal.

If using a 2L version, wire to the A or B terminal beneath the bus terminal blocks you want to contact with that CCI.

- Turn on the circuit breaker to energize the *EcoSystem* Bus Supply.  $V\sim$  PWR indicator on the *EcoSystem* Bus Supply glows green when energized.



Contact closure inputs are PELV (Class 2: USA) circuits and cannot be run with mains wiring. Unless otherwise specified, the voltages do not exceed 12-35 V $\overline{\text{---}}$ . These circuits comply with the requirements of NFPA 70, National Electric Code (NEC®). Follow all applicable national and/or local wiring regulations.

## Option (OPT) Switches

Switches on the *EcoSystem* Bus Supply configure how the *EcoSystem* Bus Supply responds to contact closures. The table below describes the switches.

Switch default position is “ON”.

### OPT Switch Function

OPT	Description	Function
1	First bus (green) CCI-1 Input type	ON = Normally open <sup>1</sup> OFF = Normally closed <sup>2</sup>
2	First bus (green) CCI-2 Input type	
3 <sup>3</sup>	Second bus (blue) CCI-1 Input type	
4 <sup>3</sup>	Second bus (blue) CCI-2 Input type	
5	Emergency disable	ON = Emergency contact closure input disabled (default) OFF = Emergency contact closure input enabled
6	Override/	See step 6 on next page
7	Normal	
8		

<sup>1</sup>Normally open: Occupied = closed  
Unoccupied = open

<sup>2</sup>Normally closed: Occupied = open  
Unoccupied = closed

<sup>3</sup>Used in 2L models only

### OPT Switches

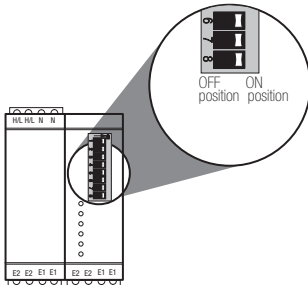

## Step 6: Testing and Troubleshooting

To confirm proper operation of your *EcoSystem* lighting network, perform the following steps:

- A. Place OPT Switches 7 and 8 into the OFF position. All ballasts and modules on the *EcoSystem* Bus should turn off (see the following table). If using a 2L version, both busses will be affected.
  - If some devices did not turn off, inspect *EcoSystem* Bus wiring at each location that did not turn off. Use a meter to determine that 17 V $\approx$  +/- 1 V $\approx$  is present between the E1 and E2 terminals at the device. Note that momentary voltage drops are normal and indicate good communication.
  - If none of the devices turn off, verify that the *EcoSystem* Bus Supply is powered ( $V \sim PWR$  indicator is on) and that the *EcoSystem* Bus is properly connected to E1 and E2 on the *EcoSystem* Bus Supply. A meter should indicate 17 V $\approx$  +/- 1 V $\approx$  between terminals E1 and E2 on the *EcoSystem* Bus Supply. If this voltage is not present, a miswire (short circuit) is likely on the *EcoSystem* Bus.
- B. After any miswires are corrected and Step A has been successfully completed, verify fixture wiring by selecting low-end override (OPT Switch 7 OFF, OPT Switch 8 ON; see table below). Leave fixtures at low end for five minutes. Verify that no lamps turn off or flash. If using a 2L version, both buses will be affected.
  - If any lamps turn off or flash, inspect ballast to lamp socket wiring. It is likely that the sockets are not properly wired. See Fluorescent Dimming Systems Technical Guide and ballast label for proper fixture wiring.

OPT 7	OPT 8	Function
ON	ON	Normal Operation (default)
ON	OFF	Override: High End
OFF	ON	Override: Low End
OFF	OFF	Override: Off

## Burn-In

After the *EcoSystem* lighting network has been successfully tested, the fluorescent lamps must be burned-in for 100 hours to remove any impurities in the lamp that may prevent proper dimming. This can be done by turning off OPT Switch 8, or starting burn-in mode using the *EcoSystem* programmer. This will force all ballasts and modules on the link to their maximum light level.

**Note:** Omitting the burn-in step may cause premature lamp failure!

## OPT Switch 6 Function

OPT Switch 6 is used to enable or disable programming via the *EcoSystem* Programmer. When OPT Switch 6 is OFF, programming is disabled. When OPT Switch 6 is ON (default position), programming is enabled via the *EcoSystem* Programmer. If using a 2L version, programming will be enabled or disabled on both buses.

OPT 6	Function
ON	Programming enabled via <i>EcoSystem</i> Programmer (default)
OFF	Programming disabled via <i>EcoSystem</i> Programmer

# EcoSystem™ | Bus Supply Installation Guide

## LED Indicators

The LEDs on the *EcoSystem* Bus Supply can be used to check for proper system operation, as described in the table below.

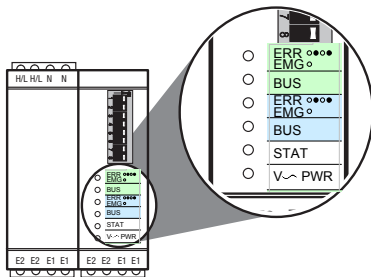

LED	Normal Operation	Problem Indicator / Probable Cause	
V~PWR	On	Off	No Mains power
STAT	Steady flash	Off	No Mains power or unit fault
		On	Unit fault
BUS	Intermittent flash or Off	On	Unit fault
ERR / EMG	Off	On	Emergency contact closure is active
		Steady flash	Miswire detected on corresponding bus

## CCI Troubleshooting Mode

When all eight OPT Switches are in the OFF position, the LEDs enter CCI troubleshooting mode, which shows the status of the contact closure inputs. CCI troubleshooting mode only affects the LED indicators, and does not affect the normal function of the OPT switches. Therefore, when in CCI troubleshooting mode, all ballasts and modules on the *EcoSystem* Bus will be in the override off state and programming will be disabled via the *EcoSystem* Programmer.

See the table below to determine the association between contact closure inputs and LEDs when in the CCI troubleshooting mode. The corresponding LED will turn ON when the corresponding contact closure is closed.

LED Indicator		Function in CCI Troubleshooting Mode
V ~ PWR		ON = Mains voltage present (always on)
STAT		ON = CCI-EMERG closed
		OFF = CCI-EMERG open
Bus 2	BUS (green)	ON = CCI-2 closed
		OFF = CCI-2 open
	ERR/EMERG (green)	ON = CCI-1 closed
		OFF = CCI-1 open
Bus 1	BUS (blue)	ON = CCI-2 closed
		OFF = CCI-2 open
	ERR/EMERG (blue)	ON = CCI-1 closed
		OFF = CCI-1 open

# EcoSystem™ | Bus Supply Installation Guide

## Lutron Electronics Co., Inc. One Year Limited Warranty

For a period of one year from the date of purchase, and subject to the exclusions and restrictions described below, Lutron warrants each new unit to be free from manufacturing defects. Lutron will, at its option, either repair the defective unit or issue a credit equal to the purchase price of the defective unit to the Customer against the purchase price of comparable replacement part purchased from Lutron. Replacements for the unit provided by Lutron or, at its sole discretion, an approved vendor may be new, used, repaired, reconditioned, and/or made by a different manufacturer.

If the unit is commissioned by Lutron or a Lutron approved third party as part of a Lutron commissioned lighting control system, the term of this warranty will be extended, and all credits against the cost of replacement parts will be prorated, in accordance with the warranty issued with the commissioned system, except that the term of the unit's warranty term will be measured from the date of its commissioning.

### EXCLUSIONS AND RESTRICTIONS

This Warranty does not cover, and Lutron and its suppliers are not responsible for:

1. Damage, malfunction or inoperability diagnosed by Lutron or a Lutron approved third party as caused by normal wear and tear, abuse, misuse, incorrect installation, neglect, accident, interference or environmental factors, such as (a) use of incorrect line voltages, fuses or circuit breakers; (b) failure to install, maintain and operate the unit pursuant to the operating instructions provided by Lutron and the applicable provisions of the National Electrical Code and of the Safety Standards of Underwriter's Laboratories; (c) use of incompatible devices or accessories; (d) improper or insufficient ventilation; (e) unauthorized repairs or adjustments; (f) vandalism; or (g) an act of God, such as fire, lightning, flooding, tornado, earthquake, hurricane or other problems beyond Lutron's control.
2. On-site labor costs to diagnose issues with, and to remove, repair, replace, adjust, reinstall and/or reprogram the unit or any of its components.
3. Equipment and parts external to the unit, including those sold or supplied by Lutron (which may be covered by a separate warranty).
4. The cost of repairing or replacing other property that is damaged when the unit does not work properly, even if the damage was caused by the unit.

EXCEPT AS EXPRESSLY PROVIDED IN THIS WARRANTY, THERE ARE NO EXPRESS OR IMPLIED WARRANTIES OF ANY TYPE, INCLUDING ANY IMPLIED WARRANTIES OF FITNESS FOR A PARTICULAR PURPOSE OR MERCHANTABILITY. LUTRON DOES NOT WARRANT THAT THE UNIT WILL OPERATE WITHOUT INTERRUPTION OR BE ERROR FREE.

NO LUTRON AGENT, EMPLOYEE OR REPRESENTATIVE HAS ANY AUTHORITY TO BIND LUTRON TO ANY AFFIRMATION, REPRESENTATION OR WARRANTY CONCERNING THE UNIT. UNLESS AN AFFIRMATION, REPRESENTATION OR WARRANTY MADE BY AN AGENT, EMPLOYEE OR REPRESENTATIVE IS SPECIFICALLY INCLUDED HEREIN, OR IN STANDARD PRINTED MATERIALS PROVIDED BY LUTRON, IT DOES NOT FORM A PART OF THE BASIS OF ANY BARGAIN BETWEEN LUTRON AND CUSTOMER AND WILL NOT IN ANY WAY BE ENFORCEABLE BY CUSTOMER.

IN NO EVENT WILL LUTRON OR ANY OTHER PARTY BE LIABLE FOR EXEMPLARY, CONSEQUENTIAL, INCIDENTAL OR SPECIAL DAMAGES (INCLUDING, BUT NOT LIMITED TO, DAMAGES FOR LOSS OF PROFITS, CONFIDENTIAL OR OTHER INFORMATION, OR PRIVACY, BUSINESS INTERRUPTION, PERSONAL INJURY, FAILURE TO MEET ANY DUTY, INCLUDING OF GOOD FAITH OR OF REASONABLE CARE, NEGLIGENCE, OR ANY OTHER PECUNIARY OR OTHER LOSS WHATSOEVER), NOR FOR ANY REPAIR WORK UNDERTAKEN WITHOUT LUTRON'S WRITTEN CONSENT ARISING OUT OF OR IN ANY WAY RELATED TO THE INSTALLATION, DEINSTALLATION, USE OF OR INABILITY TO USE THE UNIT OR OTHERWISE UNDER OR IN CONNECTION WITH ANY PROVISION OF THIS WARRANTY, OR ANY AGREEMENT INCORPORATING THIS WARRANTY, EVEN IN THE EVENT OF THE FAULT, TORT (INCLUDING NEGLIGENCE), STRICT LIABILITY, BREACH OF CONTRACT OR BREACH OF WARRANTY OF LUTRON OR ANY SUPPLIER, AND EVEN IF LUTRON OR ANY OTHER PARTY WAS ADVISED OF THE POSSIBILITY OF SUCH DAMAGES.

NOTWITHSTANDING ANY DAMAGES THAT CUSTOMER MIGHT INCUR FOR ANY REASON WHATSOEVER (INCLUDING, WITHOUT LIMITATION, ALL DIRECT DAMAGES AND ALL DAMAGES LISTED ABOVE), THE ENTIRE LIABILITY OF LUTRON AND OF ALL OTHER PARTIES UNDER THIS WARRANTY ON ANY CLAIM FOR DAMAGES ARISING OUT OF OR IN CONNECTION WITH THE MANUFACTURE, SALE, INSTALLATION, DELIVERY, USE, REPAIR, OR REPLACEMENT OF THE UNIT, OR ANY AGREEMENT INCORPORATING THIS WARRANTY, AND CUSTOMER'S SOLE REMEDY FOR THE FOREGOING, WILL BE LIMITED TO THE AMOUNT PAID TO LUTRON BY CUSTOMER FOR THE UNIT. THE FOREGOING LIMITATIONS, EXCLUSIONS AND DISCLAIMERS WILL APPLY TO THE MAXIMUM EXTENT ALLOWED BY APPLICABLE LAW, EVEN IF ANY REMEDY WOULD BE ITS ESSENTIAL PURPOSE.

### TO MAKE A WARRANTY CLAIM

To make a warranty claim, promptly notify Lutron within the warranty period described above by calling the Lutron Technical Support Center at (800) 523-9466. Lutron, in its sole discretion, will determine what action, if any, is required under this warranty. To better enable Lutron to address a warranty claim, have the unit's serial and model numbers available when making the call. If Lutron, in its sole discretion, determines that an on-site visit or other remedial action is necessary, Lutron may send a Lutron Services Co. representative or coordinate the dispatch of a representative from a Lutron approved vendor to Customer's site, and/or coordinate a warranty service call between Customer and a Lutron approved vendor.

This warranty gives you specific legal rights, and you may also have other rights which vary from state to state. Some states do not allow limitations on how long an implied warranty lasts, so the above limitation may not apply to you. Some states do not allow the exclusion or limitation of incidental or consequential damages, so the above limitation or exclusion may not apply to you.

U.S. and foreign patents pending.  
National Electrical Code (NEC) is a registered trademark of the National Fire Protection Association, Inc., Quincy, Massachusetts.

Lutron, Hi-Lume, Tu-Wire, and the sunburst logo are registered trademarks; and EcoSystem, Eco-10, Compact SE, and Onsite are trademarks of Lutron Electronics Co., Inc.

© 2007 Lutron Electronics Co., Inc.

Internet: [www.lutron.com](http://www.lutron.com)

### WORLD HEADQUARTERS

Lutron Electronics Co., Inc.  
7200 Suter Road, Coopersburg, PA  
18036-1299 USA  
TEL +1.610.282.3800  
FAX +1.610.282.1243  
Technical Support 1.800.523.9466  
Toll-Free 1.888.LUTRON1

E-mail: [product@lutron.com](mailto:product@lutron.com)

### Technical Support

USA, Canada,  
Caribbean: 1.800.523.9466  
Mexico: +1.888.235.2910  
Central/South  
America: +1.610.282.6701

### EUROPEAN HEADQUARTERS

United Kingdom  
Lutron EU Ltd.  
6 Sovereign Close, London,  
E1W 3JF UK  
TEL +44.(0)20.7702.0657  
FAX +44.(0)20.7480.8999  
Technical support  
+44.(0)20.7680.4481  
FREEPHONE 0800.282.107

### ASIAN HEADQUARTERS

Singapore  
Lutron GL Ltd.  
15 Hoe Chiang Road,  
#07-03 Euro Asia Centre,  
Singapore 089316  
TEL +65.6220.4666  
FAX +65.6220.4333

### Asia Technical Hotlines

Northern China: 10.800.712.1536  
Southern China: 10.800.120.1536  
Hong Kong: 800.901.849  
Singapore: 800.120.4491  
Taiwan: 001.137.737  
Thailand: 001.800.120.665853  
Other Areas: +65.6220.4666



Lutron Electronics Co., Inc.  
Made and printed in U.S.A.  
P/N 032-187 Rev. A 7/07