

Please refer to the enclosed CD for the product Specification Sheets and Operation Manuals, Ethernet Device IP program, and RS232 Protocol information.

PELV (Class 2: USA) Devices 12 - 24 V_{DC} 200 mA

Mounting

1. Mount the Control Interface directly on a wall, as shown in the Mounting Diagram, using screws (not included). When mounting, provide sufficient space for connecting cables. The unit can also be placed in the LUT-19AV-1U AV rack using the screws provided with the unit. The LUT-19AV-1U will hold up to four units. If conduit is desired for wiring, the LUT-5x10-ENC can be used to mount one unit.
2. Strip 3/8 in. (10 mm) of insulation from wires. Each Data Link terminal will accept up to two #18 AWG (1.0 mm²) wires.
3. Connect wiring as shown in the Wiring Diagram (next page). LED 1 lights continuously (Power) and LED 7 blinks rapidly (Data Link RX) when the Class 2 (PELV) Data Link is installed correctly.

Mounting Diagram

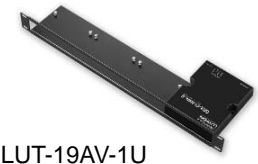
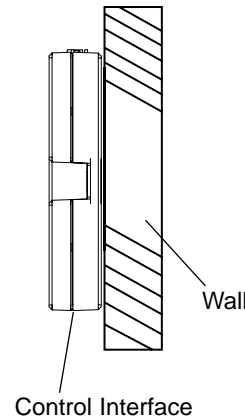

LUT-19AV-1U



LUT-5x10-ENC

Dimensions

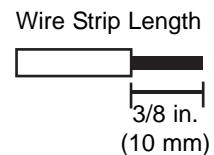
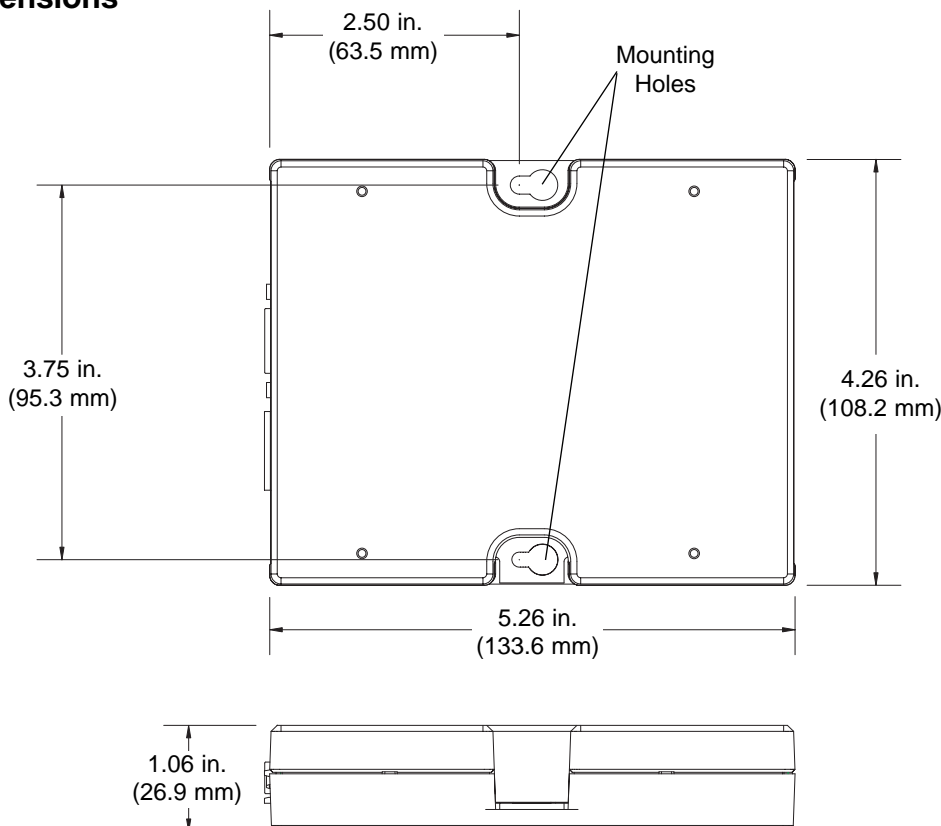

Low-Voltage PELV (Class 2: USA) Wiring

Important Notes

- Install in accordance with all applicable regulations.
- **CAUTION:** Do **not** connect line voltage/mains power to device. Improper wiring can result in personal injury or damage to the device or to other equipment.
- This control can use PELV (Class 2: USA) wiring methods. Check with your local electrical inspector for compliance with national and local codes and wiring practices.
- Make daisy-chain connections to the low-voltage PELV (Class 2: USA) Data Link terminals on the end of the Control Interface.
- Do not use T-taps. Run all wires in and out of the terminal block.
- Each terminal accepts up to two #18 AWG (1.0 mm²) wires.

Control Interface Wiring: GRX-3000 Control Unit

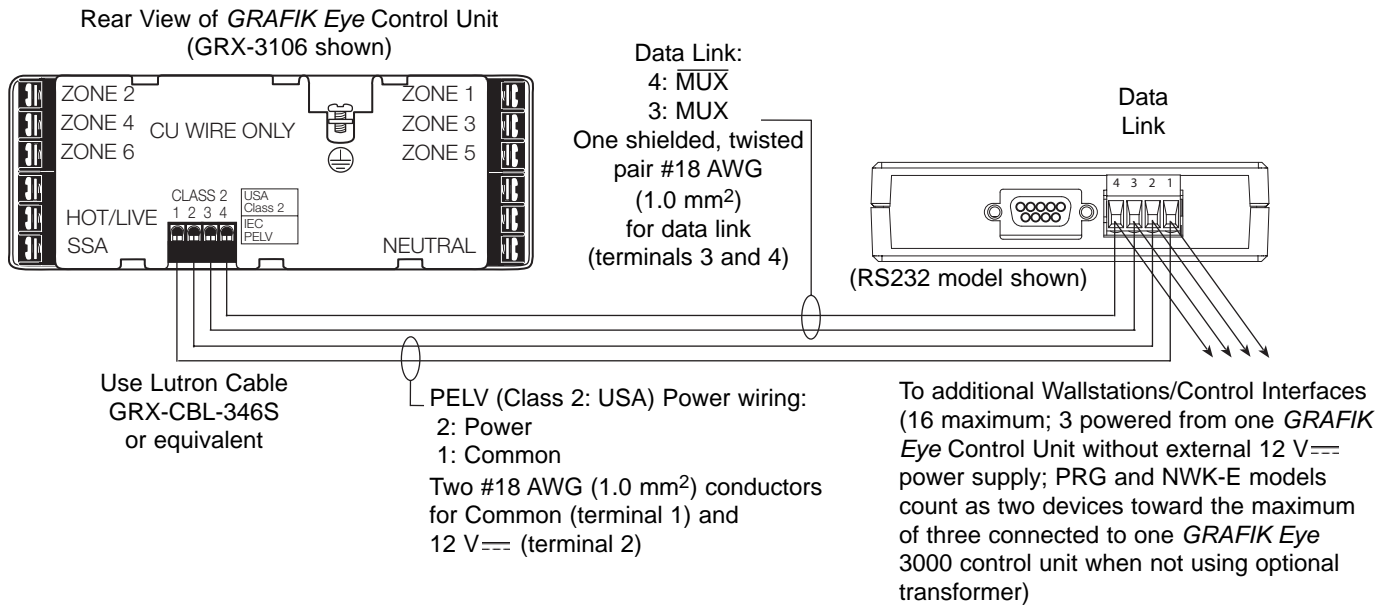

Control Interface Wiring: GRX-4000 Control Unit, OMX Control Station Device Link, or QS Link (Data Link connection shown)

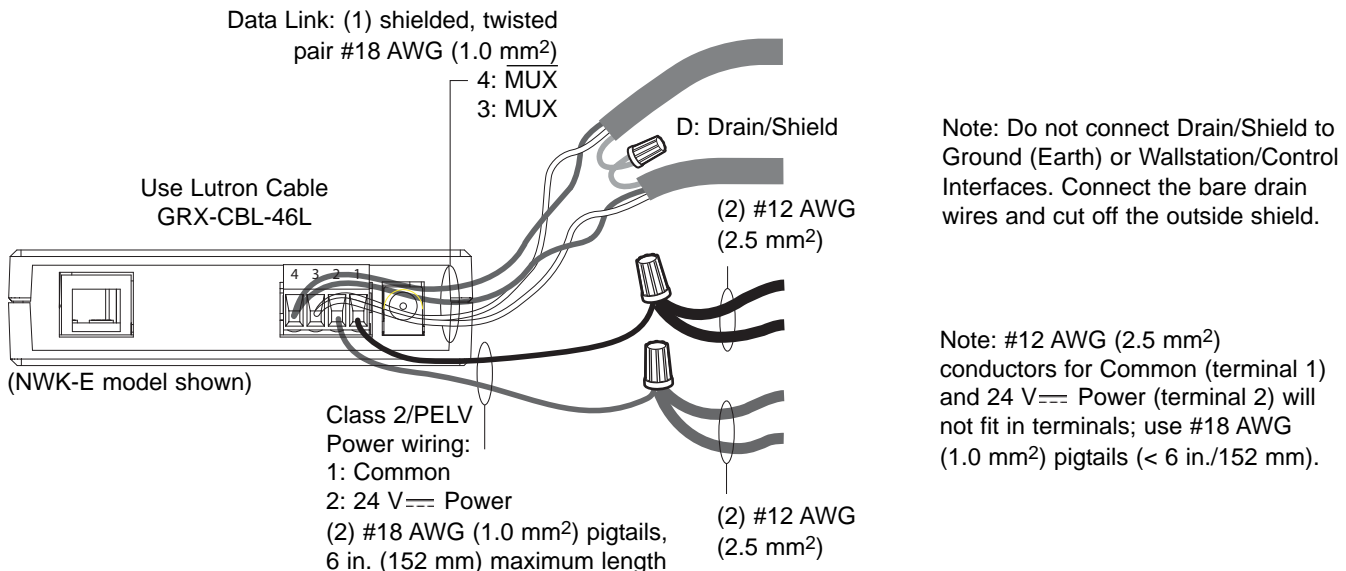

A/V Connections and Signal/Link Information

GRX-CI-NWK-E, GRX-IA-CI-NWK-E, OMX-CI-NWK-E

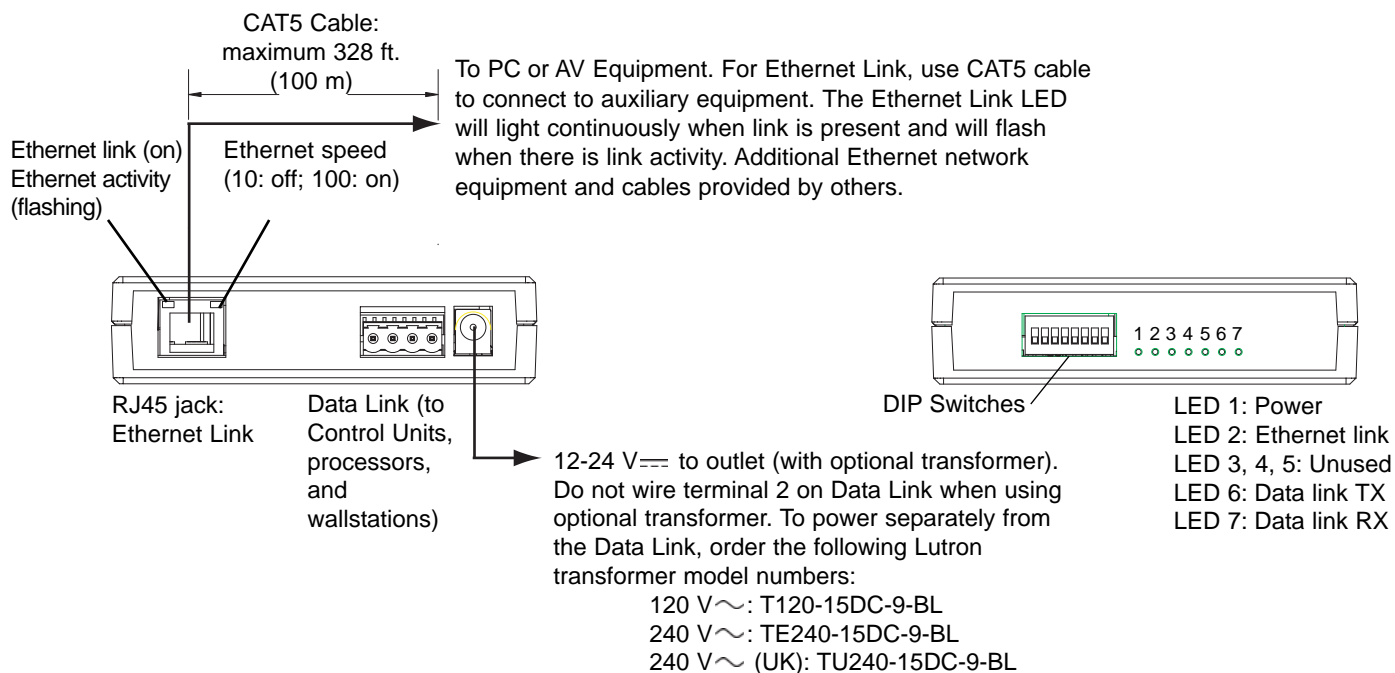

GRX-CI-RS232, GRX-IA-CI-RS232, OMX-CI-RS232

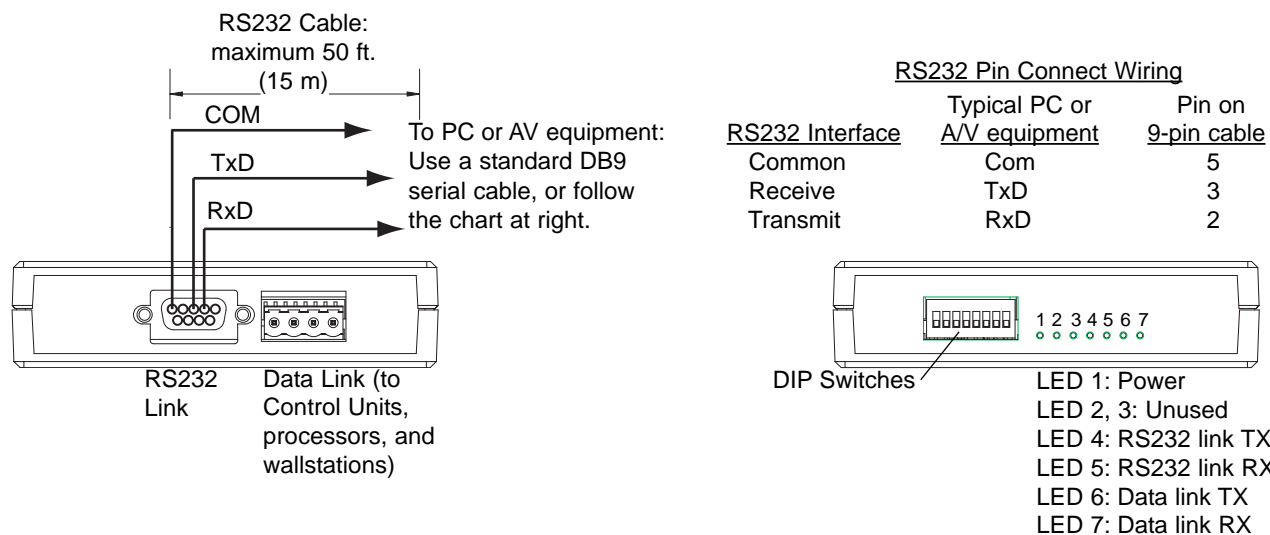

GRX-CI-PRG, GRX-IA-CI-PRG, QSE-CI-NWK-E



Please refer to the enclosed CD for the product Specification Sheets and Operation Manuals, Ethernet Device IP program, and RS232 Protocol information.

Internet: www.lutron.com
E-mail: product@lutron.com

**World Headquarters
USA**

Lutron Electronics Co., Inc.
7200 Suter Road, Coopersburg, PA
18036-1299
TEL +1.610.282.3800
FAX +1.610.282.1243
Toll-Free 1.888.LUTRON1
Technical Support 1.800.523.9466

Brazil

Lutron BZ do Brasil Ltda.
AV, Brasil, 239, Jardim America
Sao Paulo-SP, CEP: 01431-000,
Brazil
TEL +55.11.3885.5152
FAX +55.11.3887.7138

North and South America

Technical Hotlines

USA, Canada, Caribbean:
1.800.523.9466

Mexico: +1.888.235.2910
Central/South America:
+1.610.282.6701

European Headquarters

United Kingdom

Lutron EA Ltd.
6 Sovereign Close, London, E1W 3JF
United Kingdom
TEL +44.(0)20.7702.0657
FAX +44.(0)20.7480.6899
FREEPHONE (UK) 0800.282.107
Technical support
+44.(0)20.7680.4481

France

Lutron LTC, S.A.R.L.
90 rue de Villiers, 92300
Levallois-Perret France
TEL +33.(0)1.41.05.42.80
FAX +33.(0)1.41.05.01.80
FREEPHONE 0800.90.12.18

Germany

Lutron Electronics GmbH,
Landsberger Allee 201, 13055
Berlin, Germany
TEL +49.(0)30.9710.4590
FAX +49.(0)30.9710.4591
FREEPHONE 00800.5887.6635

Italy

Lutron LDV, S.r.l.
FREEPHONE 800.979.208

**Spain, Barcelona
Lutron CC, S.R.L.**

Gran Via del Carlos III, 84, planta 3a,
08028, Barcelona, Spain
TEL +34.93.496.57.42
FAX +34.93.496.57.01
FREEPHONE 0900.948.944

Spain, Madrid

Lutron CC, S.R.L.
Calle Orense, 85, 28020
Madrid, Spain
TEL +34.91.567.84.79
FAX +34.91.567.84.78
FREEPHONE 0900.948.944

Asian Headquarters

Singapore
Lutron GL Ltd.
15 Hoe Chiang Road, #07-03 Euro
Asia Centre, Singapore 089316
TEL +65.6220.4666
FAX +65.6220.4333

China, Beijing

Lutron GL Ltd.
Beijing Representative Office
5th Floor, China Life Tower
No. 16 Chaowai Street, Chaoyang
District, Beijing 100020 China
TEL +86.10.5877.1817
FAX +86.10.5877.1816

China, Guangzhou

Lutron GL Ltd. Guangzhou
Representative Office
Suite A09, 23/F Tower A,
Centre Plaza
161 Lin He Xi Lu, Tian He District,
Guangzhou 510620 China
TEL +86.20.2885.8266
FAX +86.20.2885.8366

China, Shanghai

Lutron GL Ltd., Shanghai
Representative Office
Suite 07, 39th Floor, Plaza 66
1266 Nan Jing West Road,
Shanghai, 200040 China
TEL +86.21.6288.1473
FAX +86.21.6288.1751

China, Hong Kong

Lutron GL Ltd.
Unit 2808, 28/F,
248 Queen's Road East
Wanchai, Hong Kong
TEL +852.2104.7733
FAX +852.2104.7633

Japan

Lutron Asuka Co. Ltd.
No. 16 Kowa Building, 4F, 1-9-20
Akasaka, Minato-ku,
Tokyo 107-0052 Japan
TEL +81.3.5575.8411
FAX +81.3.5575.8420
FREEPHONE 0120.083.417

Asia Technical Hotlines

Northern China: 10.800.712.1536
Southern China: 10.800.120.1536
Hong Kong: 800.901.849
Indonesia: 001.803.011.3994
Japan: +81.3.5575.8411
Macau: 0800.401
Singapore: 800.120.4491
Taiwan: 00.801.137.737
Thailand: 001.800.120.665853
Other countries: +65.6220.4666

Lutron Electronics Co., Inc.

One Year Limited Warranty

For a period of one year from the date of purchase, and subject to the exclusions and restrictions described below, Lutron warrants each new unit to be free from manufacturing defects. Lutron will, at its option, either repair the defective unit or issue a credit equal to the purchase price of the defective unit to the Customer against the purchase price of comparable replacement part purchased from Lutron. Replacements for the unit provided by Lutron or, at its sole discretion, an approved vendor may be new, used, repaired, reconditioned, and/or made by a different manufacturer.

If the unit is commissioned by Lutron or a Lutron approved third party as part of a Lutron commissioned lighting control system, the term of this warranty will be extended, and any credits against the cost of replacement parts will be prorated, in accordance with the warranty issued with the commissioned system, except that the term of the unit's warranty term will be measured from the date of its commissioning.

EXCLUSIONS AND RESTRICTIONS

This Warranty does not cover, and Lutron and its suppliers are not responsible for:

1. Damage, malfunction or inoperability diagnosed by Lutron or a Lutron approved third party as caused by normal wear and tear, abuse, misuse, incorrect installation, neglect, accident, interference or environmental factors, such as (a) use of incorrect line voltages, fuses or circuit breakers; (b) failure to install, maintain and operate the unit pursuant to the operating instructions provided by Lutron and the applicable provisions of the National Electrical Code and of the Safety Standards of Underwriter's Laboratories; (c) use of incompatible devices or accessories; (d) improper or insufficient ventilation; (e) unauthorized repairs or adjustments; (f) vandalism; or (g) an act of God, such as fire, lightning, flooding, tornado, earthquake, hurricane or other problems beyond Lutron's control.
2. On-site labor costs to diagnose issues with, and to remove, repair, replace, adjust, reinstall and/or reprogram the unit or any of its components.
3. Equipment and parts external to the unit, including those sold or supplied by Lutron (which may be covered by a separate warranty).
4. The cost of repairing or replacing other property that is damaged when the unit does not work properly, even if the damage was caused by the unit.

EXCEPT AS EXPRESSLY PROVIDED IN THIS WARRANTY, THERE ARE NO EXPRESS OR IMPLIED WARRANTIES OF ANY TYPE, INCLUDING ANY IMPLIED WARRANTIES OF FITNESS FOR A PARTICULAR PURPOSE OR MERCHANTABILITY. LUTRON DOES NOT WARRANT THAT THE UNIT WILL OPERATE WITHOUT INTERRUPTION OR BE ERROR FREE.

NO LUTRON AGENT, EMPLOYEE OR REPRESENTATIVE HAS ANY AUTHORITY TO BIND LUTRON TO ANY AFFIRMATION, REPRESENTATION OR WARRANTY CONCERNING THE UNIT. UNLESS AN AFFIRMATION, REPRESENTATION OR WARRANTY MADE BY AN AGENT, EMPLOYEE OR REPRESENTATIVE IS SPECIFICALLY INCLUDED HEREIN, OR IN STANDARD PRINTED MATERIALS PROVIDED BY LUTRON, IT DOES NOT FORM A PART OF THE BASIS OF ANY BARGAIN BETWEEN LUTRON AND CUSTOMER AND WILL NOT IN ANY WAY BE ENFORCEABLE BY CUSTOMER.

IN NO EVENT WILL LUTRON OR ANY OTHER PARTY BE LIABLE FOR EXEMPLARY, CONSEQUENTIAL, INCIDENTAL OR SPECIAL DAMAGES (INCLUDING, BUT NOT LIMITED TO, DAMAGES FOR LOSS OF PROFITS, CONFIDENTIAL OR OTHER INFORMATION, OR PRIVACY; BUSINESS INTERRUPTION; PERSONAL INJURY; FAILURE TO MEET ANY DUTY, INCLUDING OF GOOD FAITH OR OF REASONABLE CARE; NEGLIGENCE, OR ANY OTHER PECUNIARY OR OTHER LOSS WHATSOEVER), NOR FOR ANY REPAIR WORK UNDERTAKEN WITHOUT LUTRON'S WRITTEN CONSENT ARISING OUT OF OR IN ANY WAY RELATED TO THE INSTALLATION, DEINSTALLATION, USE OF OR INABILITY TO USE THE UNIT OR OTHERWISE UNDER OR IN CONNECTION WITH ANY PROVISION OF THIS WARRANTY, OR ANY AGREEMENT INCORPORATING THIS WARRANTY, EVEN IN THE EVENT OF THE FAULT, TORT (INCLUDING NEGLIGENCE), STRICT LIABILITY, BREACH OF CONTRACT OR BREACH OF WARRANTY OF LUTRON OR ANY SUPPLIER, AND EVEN IF LUTRON OR ANY OTHER PARTY WAS ADVISED OF THE POSSIBILITY OF SUCH DAMAGES.

NOTWITHSTANDING ANY DAMAGES THAT CUSTOMER MIGHT INCUR FOR ANY REASON WHATSOEVER (INCLUDING, WITHOUT LIMITATION, ALL DIRECT DAMAGES AND ALL DAMAGES LISTED ABOVE), THE ENTIRE LIABILITY OF LUTRON AND OF ALL OTHER PARTIES UNDER THIS WARRANTY ON ANY CLAIM FOR DAMAGES ARISING OUT OF OR IN CONNECTION WITH THE MANUFACTURE, SALE, INSTALLATION, DELIVERY, USE, REPAIR, OR REPLACEMENT OF THE UNIT, OR ANY AGREEMENT INCORPORATING THIS WARRANTY, AND CUSTOMER'S SOLE REMEDY FOR THE FOREGOING, WILL BE LIMITED TO THE AMOUNT PAID TO LUTRON BY CUSTOMER FOR THE UNIT. THE FOREGOING LIMITATIONS, EXCLUSIONS AND DISCLAIMERS WILL APPLY TO THE MAXIMUM EXTENT ALLOWED BY APPLICABLE LAW, EVEN IF ANY REMEDY FAILS ITS ESSENTIAL PURPOSE.

TO MAKE A WARRANTY CLAIM

To make a warranty claim, promptly notify Lutron within the warranty period described above by calling the Lutron Technical Support Center at (800) 523-9466. Lutron, in its sole discretion, will determine what action, if any, is required under this warranty. To better enable Lutron to address a warranty claim, have the unit's serial and model numbers available when making the call. If Lutron, in its sole discretion, determines that an on-site visit or other remedial action is necessary, Lutron may send a Lutron Services Co. representative or coordinate the dispatch of a representative from a Lutron approved vendor to Customer's site, and/or coordinate a warranty service call between Customer and a Lutron approved vendor.

This warranty gives you specific legal rights, and you may also have other rights which vary from state to state. Some states do not allow limitations on how long an implied warranty lasts, so the above limitation may not apply to you. Some states do not allow the exclusion or limitation of incidental or consequential damages, so the above limitation or exclusion may not apply to you.

Lutron, the sunburst logo, and GRAFIK Eye are registered trademarks and Architrave is a trademark of Lutron Electronics Co., Inc.

© 2008 Lutron Electronics Co., Inc.



Lutron Electronics Co., Inc.
Made and printed in U.S.A. 1/08
P/N 040-242 Rev. A

