

GRX-DACPI Automatic Daylighting Control

Cover (shown open)

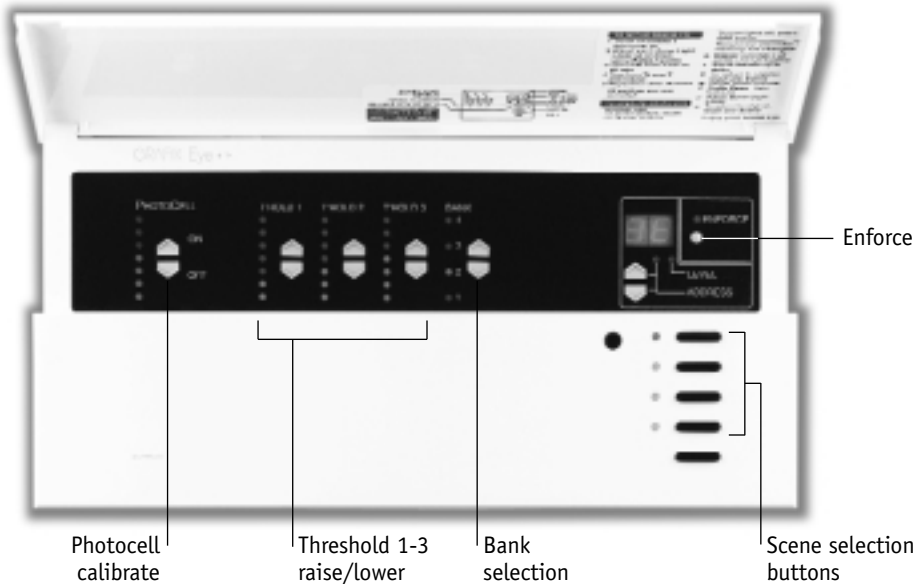

DESCRIPTION

- Saves energy in spaces with windows, skylights, or doors. Automatically dims lights when sun is bright.
- Monitors ambient daylight via Lutron’s MW-PS-WH photosensor or 0-10V photosensor by others.
- Automatically selects scenes in Control Units based on the amount of daylight available.
- Helps maximize energy savings with “enforce” mode – automatic control overrides lighting set by occupants.
- Eliminates “passing cloud” effect with a two-minute “range qualification” timer.
- Works with GRX-3000 and GRX-4000 Control Units. Can be set up to select scenes in just one Control Unit or a group of up to eight Control Units.

HOW IT WORKS

- In the GRX-DACPI Daylighting Control, you set up thresholds to define different ranges of daylight.
- In the Control Unit(s), you set up scenes to complement these levels.
- The GRX-DACPI monitors ambient light, automatically selecting scenes as daylight levels cross thresholds.

The GRX-DACPI lets you set up four “banks” of thresholds and scenes.

- You can set up three different thresholds for each bank.
- You use the bank select keys to select which bank the GRX-DACPI uses.
- The GRX-DACPI automatically selects scenes based on the bank selected and the amount of daylight available.

This gives you 12 different thresholds that call 16 different Control Unit lighting scenes. So you can create thresholds and scenes for different times of the day (morning vs. afternoon) or year (winter vs. spring).

Thresholds Define Ranges. Ranges Call Scenes.

The GRX-DACPI provides four banks. Each bank

- Lets you enter three thresholds.
- Automatically calls the four scenes shown below.

	Range 1 0-25%	Range 2 26-50%	Range 3 51-75%	Range 4 76-100%
You enter thresholds that define ranges:	Threshold 1 = 25%	Threshold 2 = 50%	Threshold 3 = 75%	
Each range calls a scene:				
Bank 1	Scene 1	Scene 2	Scene 3	Scene 4
Bank 2	Scene 5	Scene 6	Scene 7	Scene 8
Bank 3	Scene 9	Scene 10	Scene 11	Scene 12
Bank 4	Scene 13	Scene 14	Scene 15	Scene 16

JOB NAME:	MODEL NUMBERS:
JOB NUMBER:	

FUNCTIONS

Buttons and Settings	What They Do								
Scene selection buttons	Select scenes <ul style="list-style-type: none"> • 1 to 4 with bank 1 • 5 to 8 with bank 2 • 9 to 12 with bank 3 • 13 to 16 with bank 4 								
Bank selection	<ul style="list-style-type: none"> • Select which bank the GRX-DACPI uses. • LED 1 lights for bank 1, LED 2 for bank 2... 								
Threshold raise/lower	Used to setup 3 thresholds for each bank. Each threshold must be equal to or lower than the next threshold. An example is: <table border="1" style="margin-left: 20px;"> <thead> <tr> <th>Threshold</th> <th>Default Settings:</th> </tr> </thead> <tbody> <tr> <td>1</td> <td>0-25%</td> </tr> <tr> <td>2</td> <td>25-50%</td> </tr> <tr> <td>3</td> <td>50-75%</td> </tr> </tbody> </table>	Threshold	Default Settings:	1	0-25%	2	25-50%	3	50-75%
Threshold	Default Settings:								
1	0-25%								
2	25-50%								
3	50-75%								
Photocell calibrate button	Calibrates the photocell connected to the GRX-DACPI.								
Enforce toggle button and LED	Forces the GRX-DACPI to re-select the appropriate scene every 5 minutes – even if daylight levels stay the same. LED lights when enforce mode is on.								

SPECIFICATIONS

Power

Operating voltage: Low-voltage Class 2 (PELV), 12VDC to 24VFW.

Automatic Daylighting Control

- Automatically selects preset lighting scenes in response to ambient daylight.
- Provides four “banks”. Each bank provides three thresholds (levels of ambient daylight) and four scenes.
- Allows photosensor input to override manual scene selection.
- Has “Range qualification” timer. When changes in daylight cause a scene change, the GRX-DACPI waits 2 minutes before another “automatic” scene change. (Scene selection buttons work immediately.)

Photosensor Input

- Accepts
 - Up to three MW-PS-WH photosensors wired in parallel.
 - One 0-10V photosensor by others.
- Averages readings from three photosensors wired in parallel.
- Provides push-button photosensor calibration.

Key Design Features

- Meets IEC 801-2. Tested to withstand 15kV electrostatic discharge without damage or memory loss.
- Has faceplate that snaps on with no visible means of attachment.

System Communications and Capacity

Low-voltage Class 2 (PELV) wiring connects the GRX-DACPI to Control Units and other components.

Environment

32-104°F (0-40°C). 90% non-condensing relative humidity.

DIMENSIONS AND MOUNTING

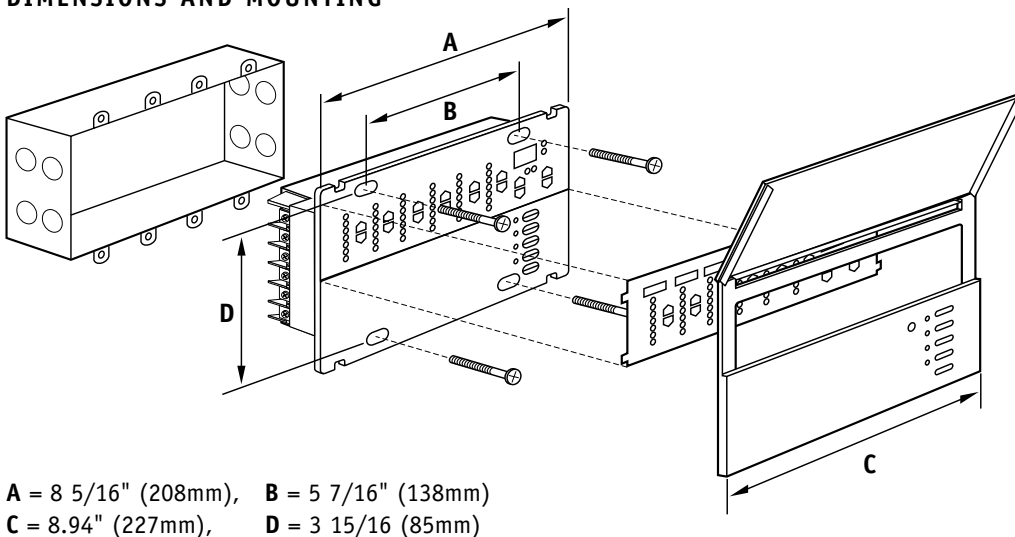

Side View

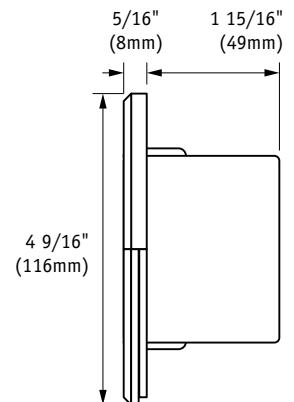

JOB NAME:	MODEL NUMBERS:
JOB NUMBER:	

WIRING FOR LUTRON MW-PS-WH PHOTOCELL

Each terminal accepts one #18 AWG (1.0mm²) wire.

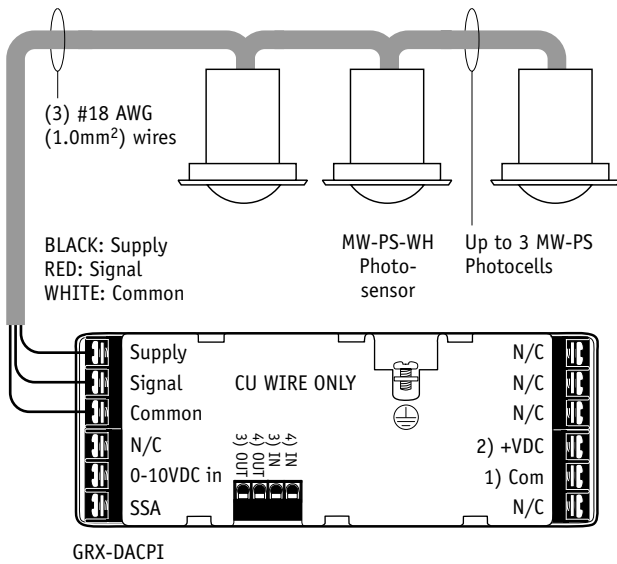

LOW-VOLTAGE CLASS 2 (PELV) WIRING

- Make daisy-chain connections to terminals on back of GRX-DACPI.
- Connect Drain/Shield as shown.
 - Do not connect to Ground (Earth) or Wallstation.
 - Connect the bare drain wires and cut off the outside shield.

Make all connections in the wallbox. Or in a switchbox or junction box with a maximum wire length of 8 feet (2.5m) from the link to the GRX-DACPI.

- Terminals 1: Common and 2: +VDC each accept two #12 AWG (2.5mm²) conductors.
- Terminals for 3 and 4 In and Out each accept one #18 AWG (1.0mm²) wire.

Terminal Connections

Terminals	When used with GRX-3000 Control Units	When used with GRX-4000 Control Units
1: Common	(2) #18 AWG (1.0mm ²) for control wiring	(2) #12 AWG (2.5mm ²) for control wiring
2: +VDC		
4: IN	(1) shielded, twisted pair #18 AWG (1.0mm ²)	(1) shielded, twisted pair #18 AWG (1.0mm ²)
3: IN		
4: OUT	for data link	for data link
3: OUT		

WIRING FOR 0-10VDC PHOTOCELL BY OTHERS

- 0-10VDC input from photo measurement equipment by other manufacturers.
- Each terminal accepts one #12 AWG (2.5mm²) wire.

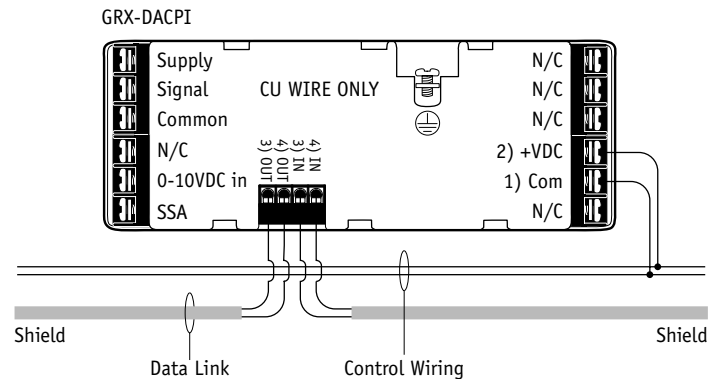
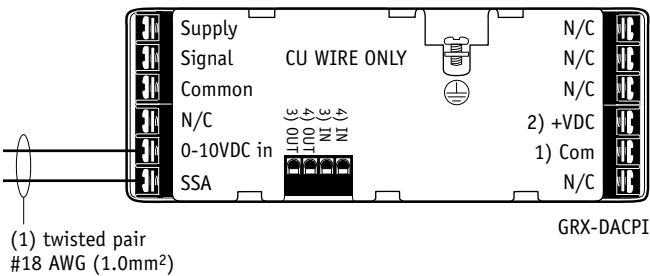

JOB NAME:	MODEL NUMBERS:
JOB NUMBER:	