

COLOR AND FINISH CODES

NTOMX-4S-IR-\_\_-\_\_\_\_  
 5-Button Wallstation with  
 Infrared Receiver

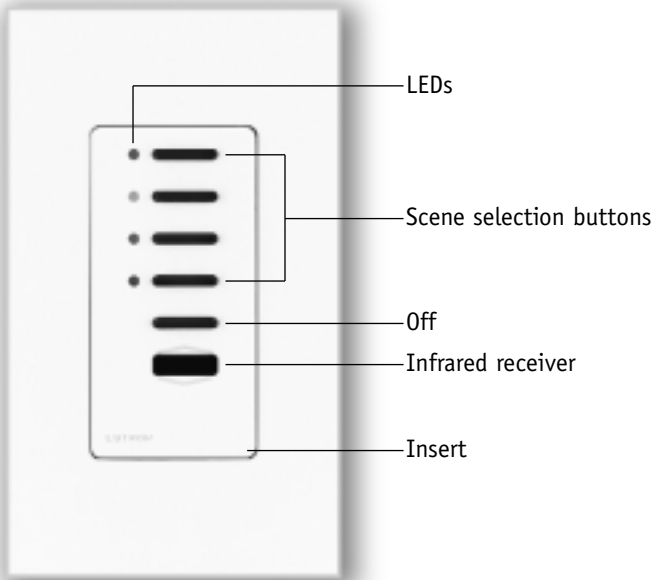

**DESCRIPTION**

Used to select and adjust scenes.

- Scene selection buttons activate scenes.
- Status LEDs show which scene is selected.
- Off button turns all lights off.
- Recalls preset light levels for four scenes plus off with four-scene Wireless Remote Control (GRX-IT) or eight scenes plus off with eight-scene Wireless Remote Control (GRX-8IT)
- Fine-tuning of light levels from Wireless Remote Control
- Can be custom-configured for other functions
- Works with Grafik 5000/6000 Systems.

**DESIGN OPTIONS**

Available with:

- Custom engraving to suit specific project needs
- Green LEDs standard, amber optional
- Sleek “no insert” faceplate (eliminates insert line)

JOB NAME:	MODEL NUMBERS:
JOB NUMBER:	

**SPECIFICATIONS**

**Power**

Operating voltage: Low-voltage Class 2 (PELV), 32VDC.

**Key Design Features**

- Meets IEC 801-2. Tested to withstand 15kV electrostatic discharge without damage or memory loss.
- Has faceplate that snaps on with no visible means of attachment.
- Can be ganged to share a common faceplate with NovaT☆ and Vareo Dimmers.

**System Communications and Capacity**

- Low-voltage Class 2 (PELV) wiring connects Wallstations to Processor Panel.
- You can link up to 32 Wallstations, Control Units, and/or Control Interfaces per Class 2 (PELV) wiring link.

**Terminals**

Capacity: Accept up to two #18 AWG (1.0mm<sup>2</sup>) typical.

**Environment**

32-104°F (0-40°C). Relative humidity less than 90% non-condensing.

**Delivery**

Ships in 4 to 6 weeks depending on system delivery.

**STANDARD COLORS AND FINISHES**

**Matte Finishes**

- White **WH**
- Ivory **IV**
- Beige **BE**
- Gray **GR**
- Brown **BR**
- Black **BL**

**Metal Finishes**

- Bright Brass **BB**
- Bright Chrome **BC**
- Bright Nickel **BN**
- Satin Brass **SB**
- Satin Chrome **SC**
- Satin Nickel **SN**
- Antique Brass **QB**
- Antique Bronze **QZ**

**Anodized Aluminum**

- Clear **CLA**
- Black **BLA**
- Brass **BRA**

- Engraving **E**
- No Insert **NI**

Custom Controls, color matching, and engraving available. Pricing and lead time may vary depending on colors, finishes, and options chosen.

**DIMENSIONS**

**Front View**

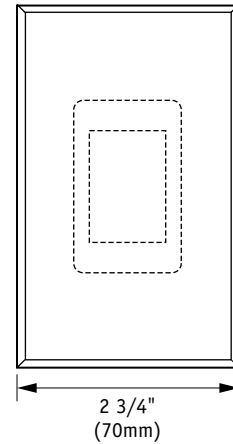

**Side View**

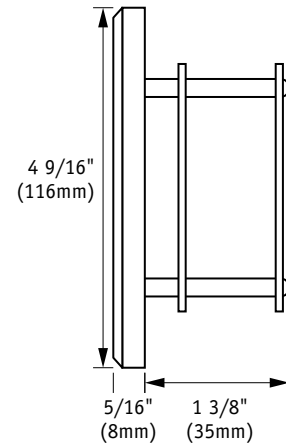

**MOUNTING**

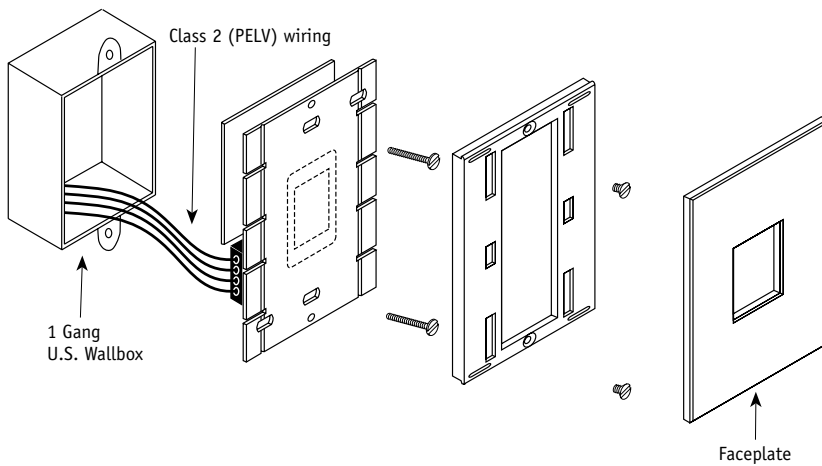

**Back View**

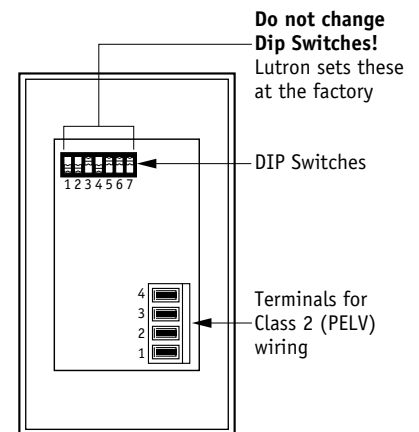

JOB NAME:	MODEL NUMBERS:
JOB NUMBER:	

**LOW-VOLTAGE CLASS 2 (PELV) WIRING**

Use low-voltage Class 2 (PELV) wiring to daisy-chain Wallstations to the Processor Panel.

- Two #12 AWG (2.5mm<sup>2</sup>) conductors for common (terminal 1) and 24VFW (terminal 2). These won't fit in terminals. Connect as shown.
- One shielded, twisted pair #18 AWG (1.0mm<sup>2</sup>) for data link (terminals 3 and 4).
- Connect Drain/Shield as shown.
  - Do not connect to Ground (Earth) or Wallstation.
  - Connect the bare drain wires and cut off the outside shield.

Note: Some Wallstations have a D terminal for Drain. You can connect the Drain/Shield at this terminal.

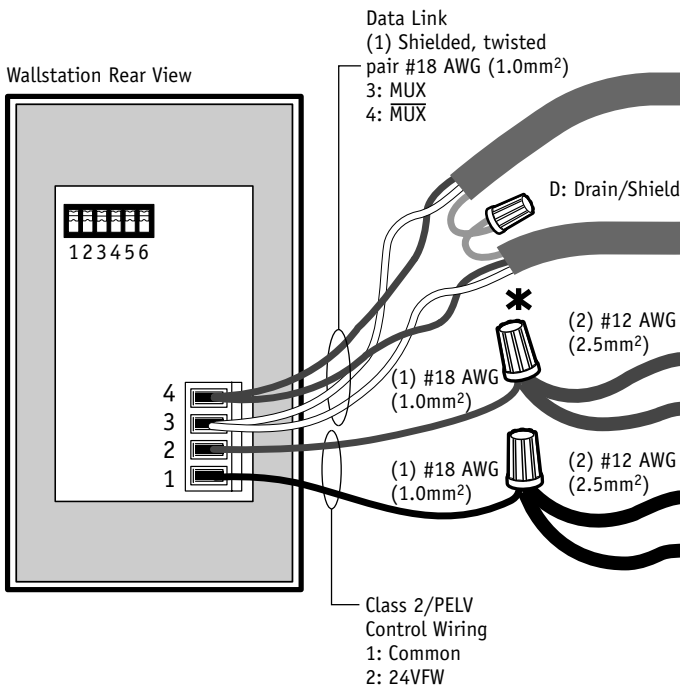

Make connections inside the wallbox. Or in a switchbox or junction box with a maximum wire length of 8 feet (2.5m) from the link to the Wallstation.

\* Use appropriate wire connecting devices as specified by local codes.

<p><b>JOB NAME:</b></p>	<p><b>MODEL NUMBERS:</b></p>
<p><b>JOB NUMBER:</b></p>	