

# OMX-AV Control Interface

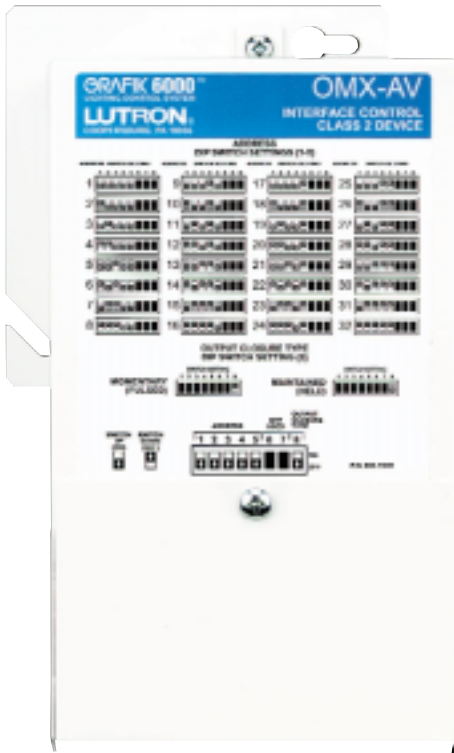

## DESCRIPTION

Integrates Grafik 5000/6000 Systems with equipment that has contact-closure I/O, including

- Motion and occupant sensors
- Timeclocks and push buttons
- Motorized projection screens, skylights, window shades, and movable walls
- AV equipment
- Fire alarm and security systems.

Provides five inputs and five outputs.

- With the inputs, contact closures in other equipment can operate Control Units:
  - Select or sequence scenes.
  - Lock Control Units.
  - Activate panic mode (lights go full on).
  - Adjust scenes to reflect status of movable walls.
  - Turn lights on or off based on room occupancy.
- With the outputs, scene changes in Control Units can:
  - Trigger outputs to control other equipment.
  - Provide status feedback to other equipment.

JOB NAME:	MODEL NUMBERS:
JOB NUMBER:	

**FUNCTIONS**

You can use the Grafik Systems Processor Panel to set up the OMX-AV Interface for different modes, functions, and momentary or maintained inputs and outputs.

**WHAT IT CAN DO**

- Gives you 5 inputs and 5 outputs for integrating equipment with contact-closure I/O.

With the inputs, contact closures in other equipment can operate controls:

- Select scenes
- Invoke panic mode (lights go full on)
- Turn lights on or off based on room occupancy
- Run sequences (Loop through scenes)
- Lock lighting controls to prevent changes
- Adjust scenes to reflect status of moveable partition walls

With the outputs, scene changes in lighting controls can:

- Trigger outputs to control other equipment
- Provide status feedback to other equipment

**WHAT IT CONNECTS TO**

- Motion sensors, occupant sensors, timeclocks, pushbuttons
- Motorized skylights, projection screens, window shades, and moveable walls
- AV equipment, fire alarm, and security systems

<p><b>JOB NAME:</b></p> <p><b>JOB NUMBER:</b></p>	<p><b>MODEL NUMBERS:</b></p>
--	------------------------------

**SPECIFICATIONS**

**Power**

Operating voltage: Low-voltage Class 2 (PELV), 32VDC.

- Provide 2-way interface between preset lighting controls and dry contact closure devices.
- Provide 5 inputs and 5 outputs. Outputs can control other manufacturers' equipment.

**Operating Modes**

Four operating modes: Scene selection, special functions, partitioning, and occupant sensor.

**Five Input Terminals**

Accept maintained inputs and momentary inputs with 40msec minimum pulse times. Switch inputs must have:

- On-state saturation voltage less than 2.0VDC.
- Off-state leakage current less than 10µA.

**Five Output Terminals**

Provide maintained outputs with a solid-state output closure and momentary outputs with a 1-second solid-state output closure:

- Provide pilot output only
- Require external relay and power supply (30 VDC maximum) by other manufacturers for contact closure
- Can drive only Class 2 (PELV) output devices that exceed 2.0VDC 200w

**Five Status LEDs**

Light when associated output is active (on).

**System Communications and Capacity**

Low-voltage Class 2 (PELV) wiring connects OMX-AV Interface to Processor Panel.

**Environment**

32-104°F (0-40°C). Relative humidity less than 90% non-condensing.

**DIMENSIONS**

Front

Side

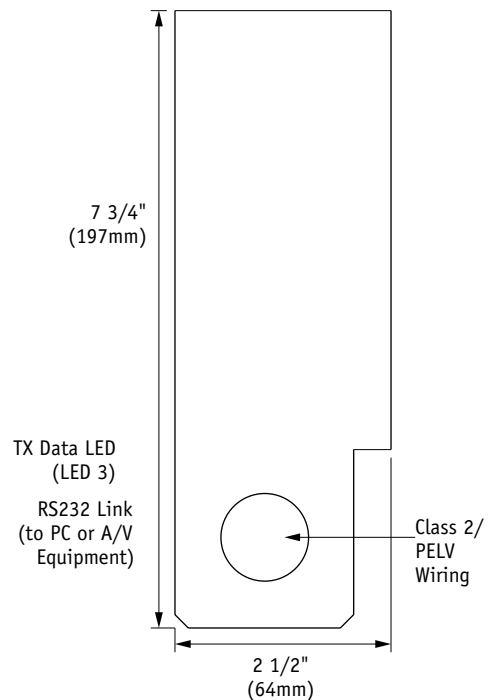
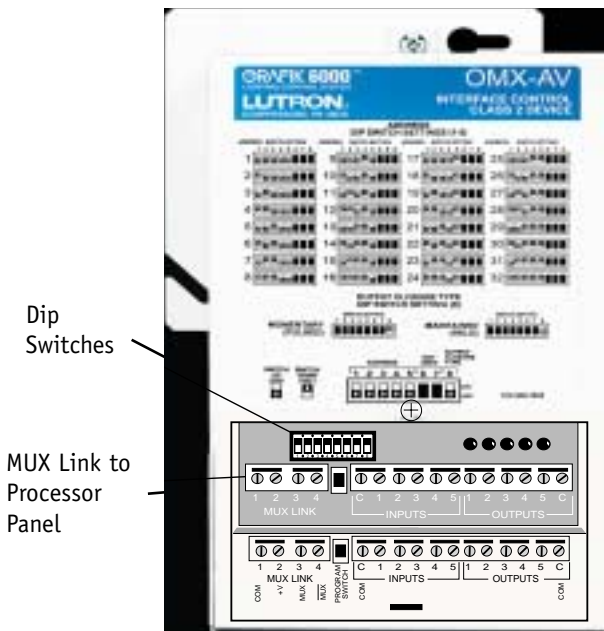

JOB NAME:	MODEL NUMBERS:
JOB NUMBER:	

**MOUNTING**

- Mount on a 4" (10.2mm) square junction box.
- Or mount directly on the wall.
- Make sure you ground the metal casing.  
Connect a ground wire to the ground screw.
- Note that wires do not feed through back of unit.

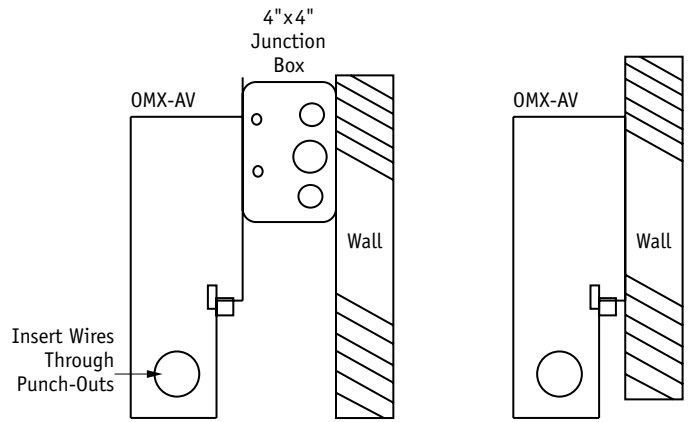

**LOW-VOLTAGE CLASS 2 (PELV) WIRING**

- Daisy-chain the OMX-AV Interface to the Class 2 (PELV) Wallstation Link that connects to the Processor Panel.
- Make daisy-chain connections to the low-voltage Class 2 (PELV) MUX Link terminals on front of OMX-AV Interface.
- Do not use T-taps. Run all wires in and out of terminal block.
- Each terminal can accept up to two #18 AWG (1.0mm<sup>2</sup>) wires.
- Consult Processor Panel Specification Submittal for more details.

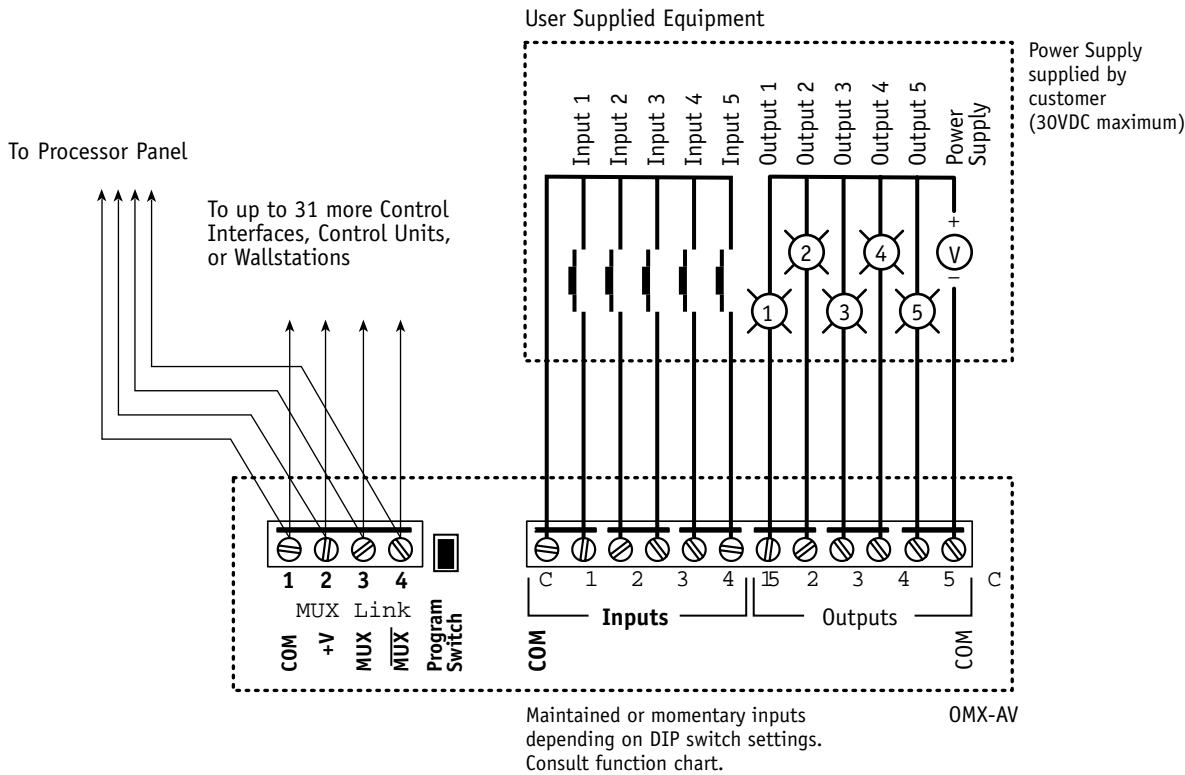

JOB NAME:	MODEL NUMBERS:
JOB NUMBER:	

**CLASS 2 (PELV) TERMINAL CONNECTIONS**

- Two #12 AWG (2.5mm<sup>2</sup>) conductors for common (terminal 1) and 32VDC (terminal 2). These won't fit in terminals. Connect as shown.
- One shielded, twisted pair #18 AWG (1.0mm<sup>2</sup>) for data link (terminals 3 and 4).
- Connect Drain/Shield as shown.
  - Do not connect to Ground (Earth) or Wallstation/Control Interfaces.
  - Connect the bare drain wires and cut off the outside shield.

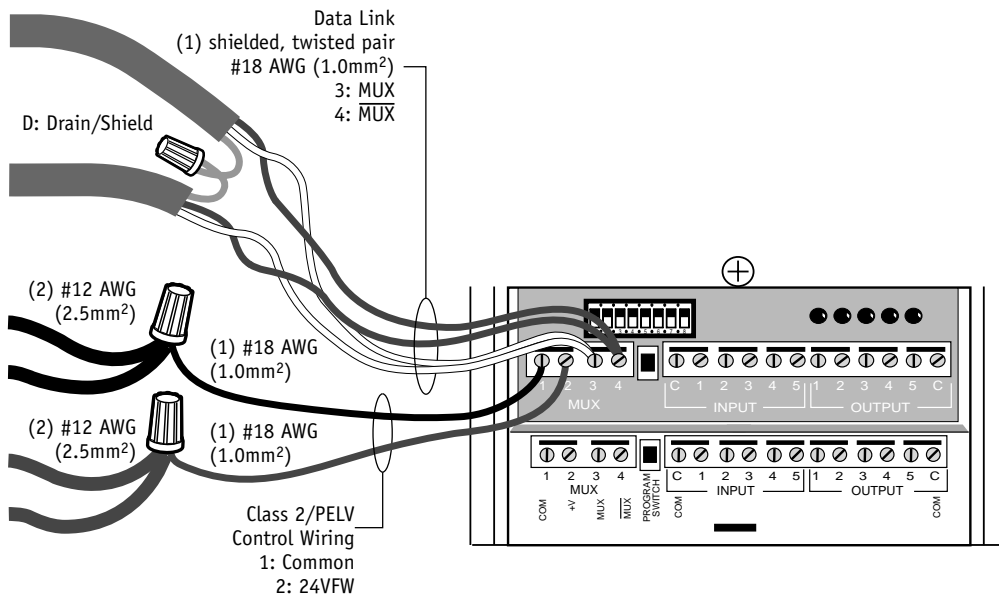

JOB NAME:	MODEL NUMBERS:
JOB NUMBER:	