

GRAFIK SERIES

LIGHTING CONTROL SYSTEM

Installation Instructions

Please Leave for Occupant

LUT-DMX

DMX-512 Interface

(Class 2/PELV Device)

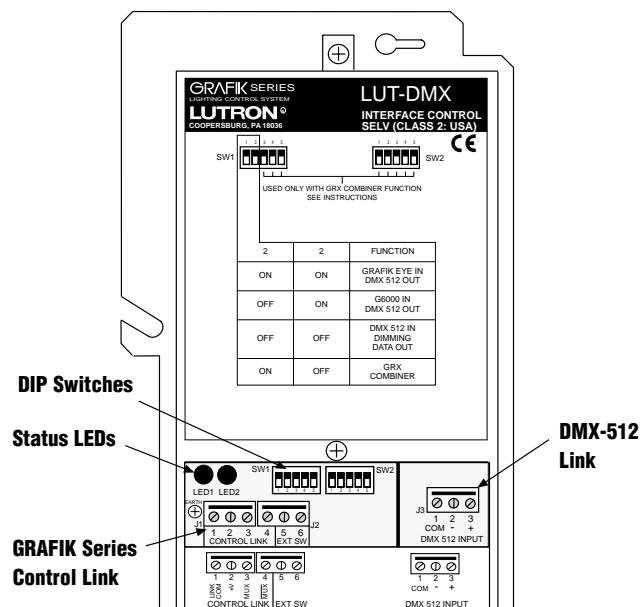

Description

The LUT-DMX Interface Control allows a Lutron *GRAFIK Eye*® 3000 Series, *GRAFIK Eye* 4000 Series, or *GRAFIK 5000/6000* System to control the output of DMX-512 equipment. The LUT-DMX can be configured to operate in two different operating modes:

1. *GRAFIK Eye* 3000/4000 Series intensity information controlling DMX-512 equipment
Note: A GRX 3500 or 4500 is necessary to achieve all intensities in the DMX-512 spectrum (see page 4). GRX 3100 or 4100 will only provide approximately 20-25 intensity values.
2. *GRAFIK 5000/6000* Dimming Panel data controlling DMX-512 equipment
- For DMX-512 input applications, contact Lutron.

Important Notes

1. Read all instructions carefully before starting installation.
2. Install in accordance with all national and local electrical codes.
3. Turn power OFF at the control panel before installing controls. Do not connect high-voltage power to any terminals on this unit. Improper wiring can result in personal injury or damage to the control and to other equipment.
4. This control can use Class 2/PELV wiring methods. Check with your local electrical inspector for compliance with local codes and wiring practices.

Installation

1. **Prewiring:** The Control Links require special wiring considerations. Refer to the *GRAFIK Eye* 3000/4000 or *GRAFIK 5000/6000* Installation Guide and Lutron job drawings for wiring restrictions that may apply to your specific project.
2. Turn power OFF.



WARNING: Always turn off the power to the control panel before doing any work. Failure to do so can result in serious personal injury and damage to equipment.

3. Mount the LUT-DMX Control to a junction box or to a wall as shown.

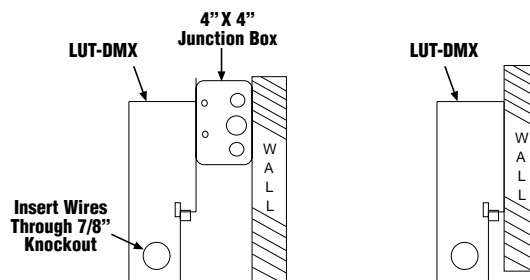

If the unit is not mounted to a metal junction box, ensure proper grounding of the metal casing by connecting a ground wire to the ground screw. Unscrew and remove the front enclosure cover to expose the terminal blocks, DIP Switch and Output Status LEDs. Insert wires through side knockouts only.

4. Strip insulation from wires so 3/8" (10 mm) bare wire is exposed. The terminals will accept up to 2 #18 (1.0 mm²) AWG wires.



If wires are larger, splice a #18 (1.0 mm²) AWG wire to the wires to make the connection.

5. Connect Control Link and external equipment wiring as shown in the **Wiring Diagrams on page 2 and 5**. Confirm all connections.
6. Replace front enclosure cover. Restore power to the control panel **after** the installation of the system is complete.

LUTRON®

Wiring Diagrams for *GRAFIK Eye 3000/4000*

Class 2 (PELV) Wiring For *GRAFIK Eye 3000/4000* Systems

Use low-voltage Class 2 (PELV) wiring for system communications.

- Make daisy-chain connections to the low-voltage Class 2 (PELV) Control Link terminals on the bottom of the LUT-DMX Interface.
- Do not use T-taps. Run all wires in and out of terminal block.
- Each terminal can accept up to two (2) #18 AWG (1.0 mm²) wires.

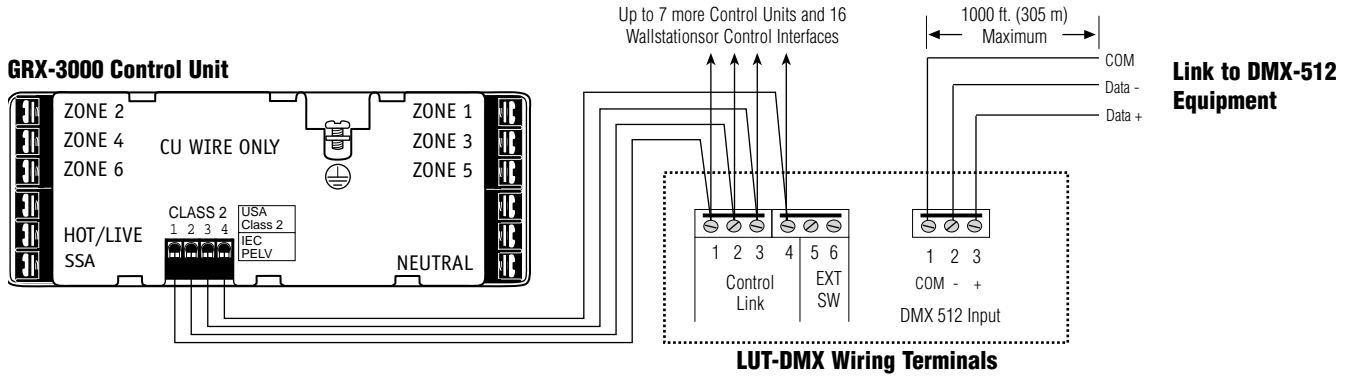

3000 Series System Wiring

- Connect 2 #18 (1.0 mm²) wires to terminals 1 (common) and 2 (12VDC).
- Connect 1 shielded, twisted pair #18 AWG (1.0 mm²) for the data link [terminals 3 (MUX) and 4 (MUX)].

4000 Series System Wiring

- Connect 1 shielded, twisted pair #18 AWG (1.0 mm²) for the data link [terminals 3 (MUX) and 4 (MUX)].
- Drain/shield must be connected as shown, but do not connect to Earth/Ground or Wallstation/Control Interfaces.
- 2 #12 AWG (2.5 mm²) power wires will not fit in the terminal blocks, however, #12 AWG (2.5 mm²) is necessary due to voltage drop on the wire. Use the diagram shown below to make the connections for terminals 1 (common) and 2 (12VDC).

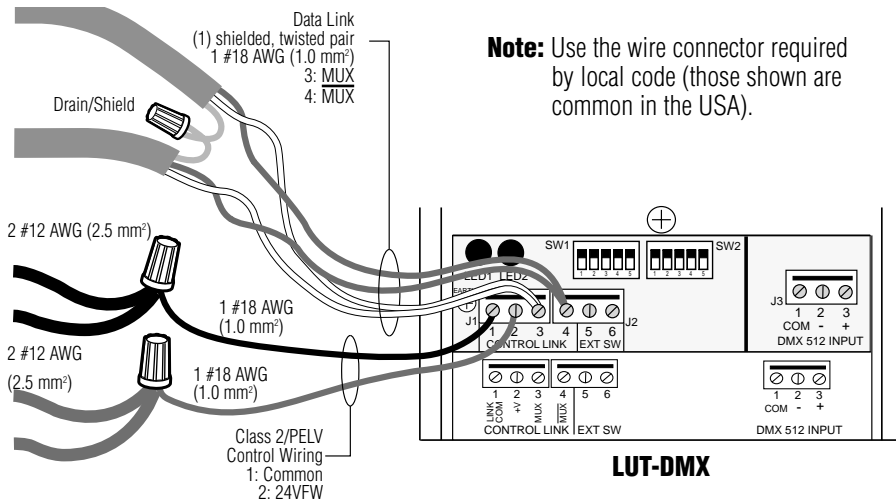

Wiring Notes:

1. Connection of the control to the Control Link should be made inside the control's wallbox or in a junction box (provided by others) located no more than 8 ft. (2.4 m) from control.
2. Control Link wiring must **not** be run in the same raceway as any high voltage wiring.

Operating Mode - *GRAFIK Eye* 3000/4000

1. *GRAFIK Eye* 3000/4000 Intensity Information Controlling DMX-512 Equipment

The LUT-DMX Interface can be placed anywhere on the Control Link of the *GRAFIK Eye* 3000 or 4000 system. LUT-DMX will read the intensities from the *GRAFIK Eye* Control Unit(s) and convert them into a DMX-512 data stream to control DMX-512 equipment.

Note: LUT-DMX is limited to the first 64 DMX-512 channels because *GRAFIK Eye* systems have a 64 zone maximum.

DIP Switch Configuration

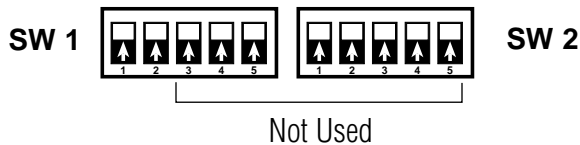

Zone to DMX-512 Channel Mapping Table

Use this table to properly configure the Control Units according to the *GRAFIK Eye* zone to DMX-512 channel equivalent.

Note: *GRAFIK Eye* 3000 is limited to the first 6 DMX-512 channels per address.

<i>GRAFIK Eye</i> Address		<i>GRAFIK Eye</i> 4000							
		<i>GRAFIK Eye</i> 3000							
A1	<i>GRAFIK Eye</i> Zone	1	2	3	4	5	6	7	8
	DMX-512 Channel	1	2	3	4	5	6	7	8
A2	<i>GRAFIK Eye</i> Zone	1	2	3	4	5	6	7	8
	DMX-512 Channel	9	10	11	12	13	14	15	16
A3	<i>GRAFIK Eye</i> Zone	1	2	3	4	5	6	7	8
	DMX-512 Channel	17	18	19	20	21	22	23	24
A4	<i>GRAFIK Eye</i> Zone	1	2	3	4	5	6	7	8
	DMX-512 Channel	25	26	27	28	29	30	31	32
A5	<i>GRAFIK Eye</i> Zone	1	2	3	4	5	6	7	8
	DMX-512 Channel	33	34	35	36	37	38	39	40
A6	<i>GRAFIK Eye</i> Zone	1	2	3	4	5	6	7	8
	DMX-512 Channel	41	42	43	44	45	46	47	48
A7	<i>GRAFIK Eye</i> Zone	1	2	3	4	5	6	7	8
	DMX-512 Channel	49	50	51	52	53	54	55	56
A8	<i>GRAFIK Eye</i> Zone	1	2	3	4	5	6	7	8
	DMX-512 Channel	57	58	59	60	61	62	63	64

LED Indicators

Use this table to check the status of the LUT-DMX once it has been installed.

Status	LED 1	LED 2
No Power	OFF	OFF
Power but no input Data	ON	OFF
Normal Operation	OFF	Flashing

Programming - *GRAFIK Eye 3000/4000*

The following tables are guides to programming *GRAFIK Eye 3000/4000* Systems to control DMX-512 equipment intensities. Although specific DMX-512 intensities are not accessible through the LUT-DMX Control Interface, the entire range of the intensity spectrum is available.

Note: 1. These values will only match directly as shown if programmed through a GRX-PRG (with LIAISON™ software) Interface Control.

2. Programming from a *GRAFIK Eye 3000/4000* Control Unit **may not** reflect the exact DMX-512 intensities listed below.

GRX Intensity	DMX-512 Intensity
0	0
1	4
2	6
3	8
4	12
5	14
6	16
7	18
8	22
9	24
10	26
11	30
12	32
13	34
14	36
15	40
16	42
17	44
18	48
19	50
20	52
21	54
22	58
23	60
24	62
25	64
26	68
27	70
28	74
29	76
30	78
31	80
32	84
33	86
34	88
35	90
36	94
37	96
38	98
39	100
40	104
41	106
42	108
43	112
44	114
45	116
46	118
47	122
48	124
49	126

GRX Intensity	DMX-512 Intensity
50	128
51	132
52	134
53	136
54	140
55	142
56	144
57	146
58	150
59	152
60	154
61	158
62	160
63	162
64	164
65	168
66	170
67	172
68	176
69	178
70	180
71	182
72	186
73	188
74	190
75	192
76	196
77	198
78	202
79	204
80	206
81	208
82	210
83	214
84	216
85	218
86	222
87	224
88	226
89	228
90	232
91	234
92	236
93	240
94	242
95	244
96	248
97	250
98	252
99	255

Wiring Diagrams for *GRAFIK 5000/6000* Systems

Class 2 (PELV) Wiring For *GRAFIK 5000/6000* Systems

Use low-voltage Class 2 (PELV) wiring for system communications.

- Make daisy-chain connections to the low-voltage Class 2 (PELV) Control Link terminals on the bottom of the LUT-DMX Interface.
- Do not use T-taps. Run all wires in and out of terminal block.
- Each terminal can accept up to 2 #18 AWG (1.0 mm²) wires. The #12 AWG (2.5 mm²) wires will not fit.

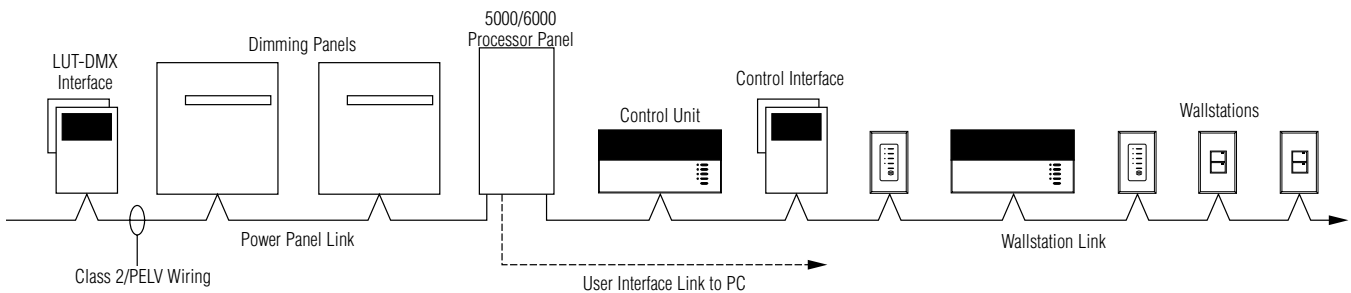

When used with *OMX-5000/6000* Control Units

- Connect 2 #18 (1.0 mm²) wires to terminals 1 (common) and 2 (32VDC).
- Connect 1 shielded, twisted pair #18 AWG (1.0 mm²) for the data link [terminals 3 (MUX) and 4 (MUX)].

Caution! No Sense Line! Run the extra #18 AWG (1.0mm²) wire used as a “sense line” for emergency (essential) lighting only between Power Panels! Do not connect this to the LUT-DMX!

- Connect Drain/Shield as shown. The Shield must be maintained throughout the Control Link.
 - Do not connect to Ground (Earth) or Wallstation/Control Interfaces. Connect the bare drain wires and cut off the outside shield.

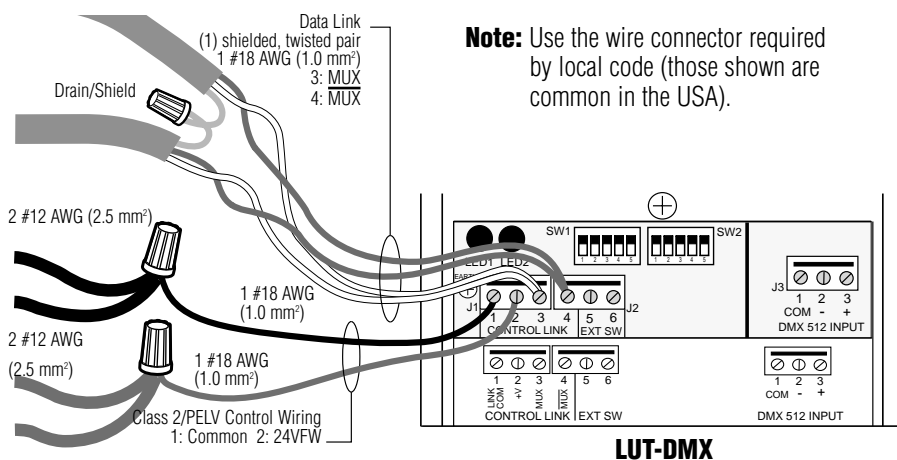

Wiring Notes:

1. Connection of the control to the Control Link should be made inside the control's wallbox or in a junction box (provided by others) located no more than 8 ft. (2.4 m) from control.
2. Control Link wiring must **not** be run in the same raceway as any high voltage wiring.
3. Total **Control Link** length is not to exceed 2000 ft. (610 m) unless signal is boosted using a link booster (MX-RPTR). **This applies only to *GRAFIK 6000*® Systems.**
4. Total **DMX-512 Link** length (between LUT-DMX and DMX-512 equipment) is not to exceed 1000 ft. (305 m) unless signal is boosted using a link booster (MX-RPTR). **This applies only to *GRAFIK 6000* Systems.**
5. Make sure you put the LUT-DMX Interface on the Power Panel Link.
6. Use Link Terminators at the beginning and end of the DMX-512 Link.

Operating Mode - *GRAFIK 5000/6000* Systems

2. *GRAFIK 5000/6000* Input Controlling DMX-512 Equipment

The LUT-DMX Interface can be placed anywhere on the Dimming Panel Link of the *GRAFIK 5000/6000* System. LUT-DMX will read the intensities from the *GRAFIK 5000/6000* Control Unit(s) and convert them into a DMX-512 data stream to control DMX-512 equipment.

GRAFIK 6000 Zone to DMX-512 Channel Mapping

GRAFIK 5000/6000 zones are mapped to DMX-512 channels on a 1 to 1 basis.

GRAFIK 5000/6000 zone # = DMX-512 channel

Note: LUT-DMX will translate **all** 512 *GRAFIK 6000* zones to DMX-512 channels for *GRAFIK 6000*. LUT-DMX will translate all 128 *GRAFIK 5000* zones to the first 128 DMX-512 channels.

DIP Switch Configuration

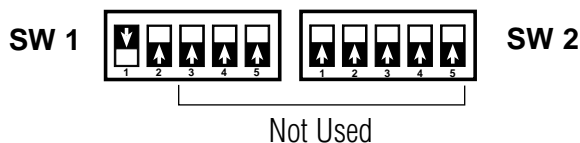

LED Indicators (located near the bottom of the LUT-DMX)

Use this table to check the status of the LUT-DMX once it has been installed.

Status	LED 1	LED 2
No Power	OFF	OFF
Power but no input Data	ON	OFF
Normal Operation	OFF	Flashing

Programming - *GRAFIK 5000/6000 Systems*

The following tables are guides to programming *GRAFIK 5000/6000* Systems to control DMX-512 equipment intensities. Although specific DMX-512 intensities are not accessible through the LUT-DMX Control Interface, the entire range of the intensity spectrum is available.

OMX Intensity	DMX-512 Intensity
OFF	0
0	2
1	4
2	6
3	10
4	12
5	14
6	16
7	20
8	22
9	24
10	26
11	30
12	32
13	34
14	36
15	40
16	42
17	44
18	46
19	50
20	52
21	54
22	56
23	60
24	62
25	64
26	66
27	70
28	72
29	74
30	76
31	80
32	82
33	84
34	88
35	90
36	92
37	94
38	98
39	100
40	102
41	104
42	108
43	110
44	112
45	114
46	118
47	120
48	122
49	124

OMX Intensity	DMX-512 Intensity
50	128
51	130
52	132
53	134
54	138
55	140
51	142
57	144
58	148
59	150
60	152
61	154
62	158
63	160
64	162
65	164
66	168
67	170
68	172
69	176
70	178
71	180
72	182
73	186
74	188
75	190
76	192
77	196
78	198
79	200
80	202
81	206
82	208
83	210
84	212
85	216
86	218
87	220
88	222
89	226
90	228
91	230
92	232
93	236
94	248
95	240
96	242
97	246
98	248
99	250
100	255

Internet: www.lutron.com
E-mail: product@lutron.com

WORLD HEADQUARTERS
Lutron Electronics Co. Inc.,
TOLL FREE: (800) 523-9466
(U.S.A., Canada, Caribbean)
Tel: (610) 282-3800;
International ++1-610-282-3800
Fax: (610) 282-1243;
International ++1-610-282-1243

GREAT BRITAIN
Lutron EA Ltd.,
Tel: (171) 702-0657;
International ++44-(0)207-702-0657
Fax: (171) 480-6899;
International ++44-(0)207-480-6899

GERMANY
Lutron Electronics GmbH
Tel: (309) 710-4590;
International ++49-30-97-10-4590
Fax: (309) 710-4591;
International ++49-30-97-10-4591

FRANCE
Lutron LTC
International ++33-(0)1-44-70-71-86
Int'l Fax: ++33-(0)1-44-70-70-97

ASIAN HEADQUARTERS
Lutron Asuka Corporation (Japan)
Tel: (03) 5405-7333;
International ++81-3-5405-7333
Fax: (03) 5405-7496;
International ++81-3-5405-7496

HONG KONG SALES OFFICE
Lutron GL (Hong Kong)
Tel: 2104-7733;
International ++852-2104-7733
Fax: 2104-7633;
International ++852-2104-7633

SINGAPORE
Lutron GL (Singapore)
Tel: ++65-220-4666
Fax: ++65-220-4333

LIMITED WARRANTY

Lutron will, at its option, repair or replace any unit that is defective in materials or manufacture within one year after purchase. For warranty service, return unit to place of purchase or mail to Lutron at 7200 Suter Rd., Coopersburg, PA 18036-1299, postage pre-paid.

This warranty is in lieu of all other express warranties, and the implied warranty of merchantability is limited to one year from purchase. This warranty does not cover the cost of installation, removal or reinstallation, or damage resulting from misuse, abuse, or improper or incorrect repair, or damage from improper wiring or installation. This warranty does not cover incidental or consequential damages. Lutron's liability on any claim for damages arising out of or in connection with the manufacture, sale, installation, delivery, or use of the unit shall never exceed the purchase price of the unit.

This warranty gives you specific legal rights, and you may also have other rights which vary from state to state. Some states do not allow limitations on how long an implied warranty lasts, so the above limitation may not apply to you. Some states do not allow the exclusion or limitation of incidental or consequential damages, so the above limitation or exclusion may not apply to you.

This product may be covered by one or more of the following U.S. patents: 4,797,599; 4,803,380; 4,893,062; 5,191,265; 5,430,356; 5,463,286; 5,530,332; 5,808,417; 5,949,200; 5,990,635; 6,046,550; 6,188,181; DES 308,647; DES 310,349; DES 311,170; DES 311,371; DES 311,382; DES 311,485; DES 311,678; DES 313,738; DES 317,593; DES 335,867; DES 344,068; DES 344,264; DES 370,663; DES 378,814; DES 387,736; DES 412,315; DES 412,491 and corresponding foreign patents. U.S. and foreign patents pending.

Lutron, GRAFIK 6000, and GRAFIK Eye are registered trademarks; GRAFIK 5000/6000 and Liaison are trademarks of Lutron Electronics Co., Inc.

© 2001 Lutron Electronics Co., Inc.

LUTRON®

Lutron Electronics Co., Inc.
Made and printed in U.S.A.
P/N 040-177 Rev. A 6/01